

Consent Agenda

March 2, 2021

MET IN REGULAR SESSION

The Board of Supervisors met in regular session at 10:00 A.M. All members present. Chairman Belt presiding.

PLEDGE OF ALLEGIANCE

1. CONSENT AGENDA

After discussion was held by the Board, a Motion was made by Shea, and seconded by Schultz, to approve:

- A. February 23, 2021, Minutes as read.
- B. Publication of Pottawattamie County Salary Listing for 2020

UNANIMOUS VOTE. Motion Carried

2. SCHEDULED SESSIONS

After Discussion was held by the Board, a motion was made by Shea, and seconded by Grobe, to approve second consideration of **Ordinance No. 2021-01**, AN ORDINANCE to amend Chapter 8 of the Pottawattamie County, Iowa Zoning Ordinance, by adding a provision that temporary roadside fireworks stands and Christmas Tree lots are a principle use in the class I-1 (General Industrial) District; and to adopt **Ordinance No. 2021-01** into law. Said ordinance is laid out as follows:

**POTTAWATTAMIE COUNTY, IOWA
ORDINANCE NO. 2021-01**

AN ORDINANCE to amend Chapter 8, of Pottawattamie County, Iowa Zoning Ordinance, by adding provisions that Temporary roadside fireworks stands and Christmas tree lots, when approved by the Development Director for a specified time period, after which they shall be disassembled and removed at the end of the authorized period each year are a principal use in the I-1 District.

**BE IT ORDAINED BY THE BOARD OF SUPERVISORS OF POTTAWATTAMIE COUNTY,
IOWA**

SECTION 1 - AMENDMENTS: That the Pottawattamie County, Iowa, Code, be and the same is hereby amended by adding thereto the following new Section, to be codified as Section 8.055.020.20 T., Principal Use in the I-1 (General Industrial) District:

- 8.055.020.20 PRINCIPAL USES: The following principal uses shall be permitted in a Class I-1 District:
- I. Temporary roadside fireworks stands and Christmas tree lots, when approved by the Development Director for a specified time period, after which they shall be disassembled and removed at the end of the authorized period each year.

SECTION 2 - SEVERABILITY: That should any section or provision of this Ordinance be declared by a court of competent jurisdiction to be invalid, that decision shall not effect that validity of the Ordinance as a whole or any part thereof, other than the part so declared to be invalid.

SECTION 3 - REPEAL OF CONFLICTING ORDINANCES: That all ordinance or parts of ordinances in conflict with the provisions of this Ordinance are hereby repealed.

SECTION 4 - EFFECTIVE DATE: This Ordinance shall be in full force and effect after its passage, approval and publication as provided by law.

Roll Call Vote: AYES: Belt, Wichman, Grobe, Schultz, Shea. Motion Carried.

Discussion was held with Mat Wyant/Planning Director, Pam Kalstrup/Acting Planning Director, Mark Hanwright, and Jason James on rural development. Discussion only. No action taken.

Motion by Schultz, second by Shea, to open public hearing on Pottawattamie County Courthouse Campus Urban Renewal Plan.

Roll Call Vote: AYES: Belt, Wichman, Grobe, Schultz, Shea. Motion Carried.

Motion by Shea, second by Schultz, to close public hearing.

Roll Call Vote: AYES: Belt, Wichman, Grobe, Schultz, Shea. Motion Carried.

Motion by Schultz, second by Shea, to approve and authorize Board to sign **Resolution No. 13-2021** entitled: Resolution determining an area of the County to be an economic development and blighted area, and that the rehabilitation, conservation, redevelopment, development or a combination thereof, of such area is necessary in the interest of the public health, safety or welfare of the residents of the County; designating such area as appropriate for urban renewal projects; and adopting the Pottawattamie County Courthouse Campus Urban Renewal Plan.

Resolution No. 13-2021

**RESOLUTION DETERMINING AN AREA OF THE COUNTY TO
BE AN ECONOMIC DEVELOPMENT AND BLIGHTED AREA,
AND THAT THE REHABILITATION, CONSERVATION,
REDEVELOPMENT, DEVELOPMENT, OR A COMBINATION
THEREOF, OF SUCH AREA IS NECESSARY IN THE INTEREST
OF THE PUBLIC HEALTH, SAFETY OR WELFARE OF THE
RESIDENTS OF THE COUNTY; DESIGNATING SUCH AREA
AS APPROPRIATE FOR URBAN RENEWAL PROJECTS; AND
ADOPTING THE POTTAWATTAMIE COUNTY COURTHOUSE
CAMPUS URBAN RENEWAL PLAN**

WHEREAS, this Board has reasonable cause to believe that the area described below satisfies the eligibility criteria for designation as an urban renewal area under Iowa law; and

WHEREAS, a proposed Pottawattamie County Courthouse Campus Urban Renewal Plan ("Plan" or "Urban Renewal Plan") for the Pottawattamie County Courthouse Campus Urban Renewal Area ("Area" or "Urban Renewal Area") described below has been prepared, which proposed Plan has been on file in the office of the County Auditor, and which proposed Plan is attached hereto as Exhibit 1 and which is incorporated herein by reference; and

WHEREAS, the purpose of the Plan is to form the Pottawattamie County Courthouse Campus Urban Renewal Area suitable for blight remediation activities and to include a list of proposed projects to be undertaken within the Urban Renewal Area, and a copy of the Plan has been placed on file for public inspection in the office of the County Auditor; and

WHEREAS, the property proposed to be included in the Urban Renewal Area is legally described in the Plan and this Board has reasonable cause to believe that the Area described in the Plan satisfies the eligibility criteria for designation as an urban renewal area under Iowa law; and

WHEREAS, the proposed Area is within two miles of the corporate boundaries the City of Council Bluffs, Iowa, and accordingly, the County has received the consent of the City of Council Bluffs in the form of a joint agreement to allow the County to operate within the proposed Area, which agreement is hereby approved in all respects and incorporated herein by this reference; and

WHEREAS, it is desirable that the Urban Renewal Area be redeveloped as described in the proposed Urban Renewal Plan to be known hereafter as the "Pottawattamie County Courthouse Campus Urban Renewal Plan"; and

WHEREAS, the Iowa statutes require the Board of Supervisors to submit the proposed Urban Renewal Plan to the Planning and Zoning Commission for review and recommendation as to its conformity with the general plan for development of the County as a whole, prior to Board of Supervisors approval thereof; and

WHEREAS, creation of the Urban Renewal Area and adoption of the Urban Renewal Plan therefore has been approved by the Planning and Zoning Commission for the County as being in conformity

with the general plan for development of the County as a whole, as evidenced by its written report and recommendation filed herewith, which report and recommendation is hereby accepted, approved in all respects and incorporated herein by this reference; and

WHEREAS, by resolution adopted on February 2, 2021, this Board directed that a consultation be held with the designated representatives of all affected taxing entities to discuss the proposed Urban Renewal Plan and the division of revenue described therein, and that notice of the consultation and a copy of the proposed Urban Renewal Plan be sent to all affected taxing entities; and

WHEREAS, pursuant to such notice, the consultation was duly held as ordered by the Board of Supervisors and all required responses to the recommendations made by the affected taxing entities, if any, have been timely made as set forth in the report of Chairperson Scott Belt, or his delegate, filed herewith and incorporated herein by this reference, which report is in all respects approved; and

WHEREAS, by resolution this Board also set a public hearing on the adoption of the proposed Urban Renewal Plan for this meeting of the Board, and due and proper notice of the public hearing was given, as provided by law, by timely publication in The Daily Nonpareil, The Avoca Journal Herald, and The Oakland Herald, which notice set forth the time and place for this hearing and the nature and purpose thereof; and

WHEREAS, in accordance with the notice, all persons or organizations desiring to be heard on the proposed Urban Renewal Plan, both for and against, have been given an opportunity to be heard with respect thereto and due consideration has been given to all comments and views expressed to this Board in connection therewith and the public hearing has been closed.

NOW, THEREFORE, BE IT RESOLVED, BY THE BOARD OF SUPERVISORS OF POTTAWATTAMIE COUNTY, STATE OF IOWA:

Section 1. That the findings and conclusions set forth or contained in the proposed "Pottawattamie County Courthouse Campus Urban Renewal Plan" for the area of Pottawattamie County, State of Iowa, legally described and depicted in the Plan and incorporated herein by reference (which area shall hereinafter be known as the "Pottawattamie Courthouse Campus Urban Renewal Area"), be and the same are hereby adopted and approved as the findings of this Board for this area.

Section 2. This Board further finds:

a) Although relocation is not expected, a feasible method exists for the relocation of any families who will be displaced from the Urban Renewal Area into decent, safe and sanitary dwelling accommodations within their means and without undue hardship to such families;

b) The Urban Renewal Plan conforms to the general plan for the development of the County as a whole; and

c) Acquisition of additional land within the Urban Renewal Area by the County is not immediately expected, because the County already owns the land within the Urban Renewal Area.

Section 3. That the Urban Renewal Area is an economic development and blighted area within the meaning of Chapter 403, Code of Iowa; that such area is eligible for designation as an urban renewal area and otherwise meets all requisites under the provisions of Chapter 403, Code of Iowa; and that the rehabilitation, conservation, redevelopment, development, or a combination thereof, of such area is necessary in the interest of the public health, safety or welfare of the residents of this County.

Section 4. That the Urban Renewal Plan, attached hereto as Exhibit 1 and incorporated herein by reference, be and the same is hereby approved and adopted as the "Pottawattamie County Courthouse Campus Urban Renewal Plan for the Pottawattamie Courthouse Campus Urban Renewal Area"; the Urban Renewal Plan for such area is hereby in all respects approved; the Chairperson and County Auditor are authorized to execute the Joint City-County Agreement; and the County Auditor is hereby directed to file a certified copy of the Urban Renewal Plan with the proceedings of this meeting.

Section 5. That, notwithstanding any resolution, ordinance, plan, amendment or any other document, the original Urban Renewal Plan shall be in full force and effect from the date of this Resolution until the Board amends or repeals the Plan. Said Urban Renewal Plan shall be forthwith certified by the County Auditor, along with a copy of this Resolution, to the Recorder for Pottawattamie County, Iowa, to be filed and recorded in the manner provided by law.

PASSED AND APPROVED this 2nd day of March, 2021.

ROLL CALL VOTE

	AYE	NAY	ABSTAIN	ABSENT
_____ Scott Belt, Chairman	○	○	○	○
_____ Tim Wichman	○	○	○	○
_____ Lynn Grobe	○	○	○	○
_____ Justin Schultz	○	○	○	○
_____ Brian Shea	○	○	○	○

ATTEST: _____
Melvyn Houser, County Auditor

Roll Call Vote: **AYES: Belt, Wichman, Grobe, Schultz, Shea. Motion Carried.**

After discussion was held by the Board, a Motion was made by Schultz, and seconded by Shea to approve and authorize Board to sign **Resolution No. 14-2021** entitled: Resolution Fixing Date for A Meeting on The Proposition of The Issuance of Not to Exceed \$16,900,000 General Obligation Urban Renewal Bonds of Pottawattamie County, State of Iowa (For Essential County Purposes), And Providing for Publication of Notice Thereof.

Resolution No. 14 - 2021

RESOLUTION FIXING DATE FOR A MEETING ON THE PROPOSITION OF THE ISSUANCE OF NOT TO EXCEED \$16,900,000 GENERAL OBLIGATION URBAN RENEWAL BONDS OF POTTAWATTAMIE COUNTY, STATE OF IOWA (FOR ESSENTIAL COUNTY PURPOSES), AND PROVIDING FOR PUBLICATION OF NOTICE THEREOF

WHEREAS, by Resolution No. 13, adopted March 2, 2021, this Board found and determined that certain areas located within the County are eligible and should be designated as an urban renewal area under Iowa law, and approved and adopted the Pottawattamie County Courthouse Campus Urban Renewal Plan (the "Plan") for the Pottawattamie County Courthouse Campus Urban Renewal Area (the "Area" or "Urban Renewal Area"), which Plan is or will be on file in the office of the Recorder of Pottawattamie County, Iowa; and

WHEREAS, it is deemed necessary and advisable that Pottawattamie County, State of Iowa, should issue General Obligation Urban Renewal Bonds, to the amount of not to exceed \$16,900,000, as authorized by Sections 331.443 and 403.12, of the Code of Iowa, for the purpose of providing funds to pay costs of carrying out essential county urban renewal purpose project(s) as hereinafter described; and

WHEREAS, before bonds may be issued, it is necessary to comply with the procedural requirements of Chapters 331 and 403 of the Code of Iowa, and to publish a notice of the proposal to issue such bonds and the right to petition for an election. **PASSED AND APPROVED** this 2nd day of March, 2021.

NOW, THEREFORE, BE IT RESOLVED BY THE BOARD OF SUPERVISORS OF POTTAWATTAMIE COUNTY, STATE OF IOWA:

Section 1. That this Board meet in the Board Room, County Courthouse, 227 South 6th Street, Council Bluffs, Iowa, at 10:00 A.M., on the 16th day of March, 2021, for the purpose of taking action on the matter of the issuance of not to exceed \$16,900,000 General Obligation Urban Renewal Bonds, for essential county purposes, the proceeds of which bonds will be used to provide funds to pay the costs of aiding in the planning, undertaking, and carrying out of urban renewal projects under the authority of Chapter 403.

Section 2. That the Auditor is hereby directed to cause at least one publication to be made of a notice of the meeting, in a legal newspaper, printed wholly in the English language, published at least once weekly, and having general circulation in the County. The publication to be not less than ten clear days nor more than twenty days before the date of the public meeting on the issuance of the Bonds.

Section 3. The notice of the proposed action to issue bonds shall be in substantially the following form:

(To be published on or before: March 6, 2021)

NOTICE OF MEETING OF THE BOARD OF SUPERVISORS OF POTTAWATTAMIE COUNTY, STATE OF IOWA, ON THE MATTER OF THE PROPOSED ISSUANCE OF NOT TO EXCEED \$16,900,000 GENERAL OBLIGATION URBAN RENEWAL BONDS OF THE COUNTY (FOR ESSENTIAL COUNTY PURPOSES), AND THE HEARING ON THE ISSUANCE THEREOF

PUBLIC NOTICE is hereby given that the Board of Supervisors of Pottawattamie County, State of Iowa, will hold a public hearing on the 16th day of March, 2021, at 10:00 A.M., in the Board Room, County Courthouse, 227 South 6th Street, Council Bluffs, Iowa, at which meeting the Board proposes to take additional action for the issuance of not to exceed \$16,900,000 General Obligation Urban Renewal Bonds, for essential county purposes, to provide funds to pay the costs of aiding in the planning, undertaking, and carrying out of urban renewal projects under the authority of Chapter 403.

At any time before the date of the meeting, a petition, asking that the question of issuing such Bonds be submitted to the legal voters of the County, may be filed with the Auditor of the County in the manner provided by Section 331.306 of the Code of Iowa, pursuant to the provisions of Sections 331.441(2)(b)(14), 331.443 and 403.12 of the Code of Iowa.

At the above meeting the Board shall receive oral or written objections from any resident or property owner of the County to the above action. After all objections have been received and considered, the Board will at the meeting or at any adjournment thereof, take additional action for the issuance of the Bonds or will abandon the proposal to issue said Bonds.

This notice is given by order of the Board of Supervisors of Pottawattamie County, State of Iowa, as provided by Chapters 331 and 403 of the Code of Iowa.

Dated this 2nd day of March, 2021.

County Auditor, Pottawattamie County,
State of Iowa

(End of Notice)

PASSED AND APPROVED this 2nd day of March, 2021.

ROLL CALL VOTE

	AYE	NAY	ABSTAIN	ABSENT
_____ Scott Belt, Chairman	○	○	○	○

_____	<input type="radio"/>	<input type="radio"/>	<input type="radio"/>	<input type="radio"/>
Tim Wichman				
_____	<input type="radio"/>	<input type="radio"/>	<input type="radio"/>	<input type="radio"/>
Lynn Grobe				
_____	<input type="radio"/>	<input type="radio"/>	<input type="radio"/>	<input type="radio"/>
Justin Schultz				
_____	<input type="radio"/>	<input type="radio"/>	<input type="radio"/>	<input type="radio"/>
Brian Shea				

ATTEST: _____
 Melvyn Houser, County Auditor

Roll Call Vote: AYES: Belt, Wichman, Grobe, Schultz, Shea. Motion Carried.

After discussion was held by the Board, a Motion was made by Wichman, and seconded by Schultz, to approve and authorize Board to sign **Resolution No. 15-2021. Resolution No. 15-2021** is laid out as follows:

Resolution No. 15 - 2021

WHEREAS, functional classification is the process by which streets and highways are grouped into classes according to the character of service they are intended to provide; and

WHEREAS, Pottawattamie County periodically reviews the system of streets and highways for appropriate changes to classification of the various segments of the system; and

WHEREAS, a recent review of the system has revealed the need for a change to the federal functional classification of road segments due to added paved routes within the City of Council Bluffs and the reconfiguration of roadways along the city limits; and

WHEREAS, the Omaha-Council Bluffs Metropolitan Area Planning Agency (MAPA) is the designated Metropolitan Planning Organization (MPO) for the Omaha-Council Bluffs Transportation Management Area (TMA); and

WHEREAS, the identified road segment is within both the county and the MAPA TMA, and

WHEREAS, MAPA has concurred with this change in MAPA Resolution 2021-25.

NOW, THEREFORE, BE IT RESOLVED that Pottawattamie County hereby requests the Iowa Department of Transportation to request the Federal Highway Administration to make the following changes in federal functional classification:

CHANGES TO FEDERAL FUNCTIONAL CLASSIFICATION SYSTEM

Cedar Ln from Proposed Steven Rd to West Urban Area boundary for a distance of 0.18 miles from **Rural Local to Rural Major Collector**

PASSED AND APPROVED this 2nd day of March, 2021.

ROLL CALL VOTE

	AYE	NAY	ABSTAIN	ABSENT
_____	<input type="radio"/>	<input type="radio"/>	<input type="radio"/>	<input type="radio"/>
Scott Belt, Chairman				
_____	<input type="radio"/>	<input type="radio"/>	<input type="radio"/>	<input type="radio"/>
Tim Wichman				
_____	<input type="radio"/>	<input type="radio"/>	<input type="radio"/>	<input type="radio"/>

Lynn Grobe

Justin Schultz

Brian Shea

○ ○ ○ ○
○ ○ ○ ○

ATTEST: _____
Melvyn Houser, County Auditor

Roll Call Vote: AYES: Belt, Wichman, Grobe, Schultz, Shea. Motion Carried.

After discussion was held by the Board, a Motion was made by Grobe, and seconded by Shea, to reappoint Bernie Bolton to the Loess Hills Development and Conservation Authority for a term of two years. UNANIMOUS VOTE. Motion Carried

After discussion was held by the Board, a Motion was made by Wichman, and seconded by Schultz, to approve and authorize Chairman to sign Farm Lease with Craig Hotze, for property legally described as: GROVE TWP 17-74-39 PT SE SE & 20-74-39 PT NE NE Comm 138.85' SE COR SEC 17 TH SW 669.08' N283.91' W 364.92' S307.35' SW276.37' SE 270.43' SW442.07' N 1934.4' E1327.46' S818.15' TO POB (INCLUDES PARCEL A SE SE PARCELS B & C NE NE) commonly referred to as Wheeler Grove Conservation Area. UNANIMOUS VOTE. Motion Carried

After discussion was held by the Board, a Motion was made by Wichman, and seconded by Schultz to approve and authorize Chairman to sign Farm Lease with Craig Hotze, for property legally described as: Tract #1, The North Half of the Northeast Quarter (N ½ NE ¼) and the North Half of the Northwest Quarter (N ½ NW ¼) of the Section 14, Township 74 North, Range 39, West of the 5th P.M.; and Tract #2, the South Half of the Southeast Quarter (S ½ SE ¼) of Section 11, Township 74, Range 39, West of the 5th P.M. UNANIMOUS VOTE. Motion Carried

After discussion was held by the Board, a Motion was made by Wichman, and seconded by Schultz to approve and authorize Chairman to sign Farm Lease with Joe Respeliars, for property legally described as: A Parcel of Land being a portion of Government Lot 7 in the South Half of the Northeast Quarter, A Portion of the Southeast Quarter, and a portion of Government Lot 6 in the Northwest Quarter of the Southeast Quarter, all in Section 23 Township 75 North, Range 44 West of the 5th Principal Meridian, City of Council Bluffs, Pottawattamie County, Iowa. UNANIMOUS VOTE. Motion Carried

3. RECEIVED/FILED

A. Salary Actions:

- 1) Communications – Payroll status change of Alicia Cotton
- 2) Public Health – Payroll status change of Melissa Castro

4. CLOSED SESSION

Motion by Wichman, second by Shea, to go into Closed Session pursuant Iowa Code 20.17(3) for discussion and/or decision on labor negotiations / collective bargaining matters.

Roll Call Vote: AYES: Belt, Wichman, Grobe, Schultz, Shea. Motion Carried.

Motion by Shea, second by Grobe, to go out of Closed Session.

Roll Call Vote: AYES: Belt, Wichman, Grobe, Schultz, Shea. Motion Carried.

5. SCHEDULED SESSIONS

Becky Lenihan/Assistant Finance Officer, Auditor's Office appeared before the board for a discussion on the FY 21/22 budget. Discussion only. No action taken.

6. ADJOURN

Motion by Shea, second by Schultz, to adjourn meeting.
UNANIMOUS VOTE. Motion Carried.

THE BOARD ADJOURNED SUBJECT TO CALL AT 2:40 P.M.

Scott Belt, Chairman

ATTEST:

Melvyn Houser, Pottawattamie County Auditor

APPROVED: March 9, 2021

PUBLISH: X

I, Melvyn Houser, Auditor of Pottawattamie County, verify the following to be a correct copy of all claims allowed by the Pottawattamie County Board of Supervisors for the month of February 2021.

Vendor Name	Payable Description	Total Payments
911 CUSTOM LLC	SUPPLIES - SHERIFF	723.00
ABBIE ASHCRAFT	REIMB EXP - SWIA MHDS REGION	2.46
ABLE LOCKSMITHS	PROF SVC - CONSERVATION	33.00
ACCURATE CONTROL INC	PROF SVC - NON DEPARTMENTAL	11,790.20
ACTION GROUP LLC	PROF SVC - SHERIFF	123.42
ADAM FIELDS	REIMB EXP - SHERIFF	95.50
ADAM KLEIN	REIMB EXP - IT	6.22
AGGRESSIVE INDUSTRIES INC	SUPPLIES - NON DEPARTMENTAL	19,603.00
AGRILAND FS INC	FUEL - CONSERVATION	1,588.00
AGRIVISION GROUP, LLC	SUPPLIES - B&G	822.48
AHLERS & COONEY PC	LEGAL SVC - BOARD	27,175.12
AIRGAS INC	ROADS/SUPPLIES	391.04
AJ CARE CORP	SUPPORT SVCS - SWIA MHDS REGION	300.00
ALEGENT CREIGHTON HEALTH	MED SVCS - JAIL	210.00
ALEGENT HEALTH BERGAN MERCY HEALTH SYSTEM	MED SVCS - JAIL	100.24
ALL COPY PRODUCTS INC	PROF SVC - CONSERVATION	87.13
ALL MAKES OFFICE EQUIPMENT CO	SUPPLIES - B&G	22.17
AM COHRON & SON INC	ROADS/PROJECT - VOUCHER 1	64,711.60
AMAZON CAPITAL SERVICES INC	SUPPLIES - DHS	556.32
AMERICAN NATIONAL BANK	MO BILL - JAIL	13,762.19
AMERISERVE INTERNATIONAL	SUPPORT SVC - SWIA MHDS REGION	1,782.00
AMERITECH SOLUTIONS	SUPPLIES - WIC	186.00
ANCHOR HOMES INC	SUPPORT SVC - SWIA MHDS REGION	6,510.00
ANN JOHNK	MEETING - BOARD	60.00
ARNOLD MOTOR SUPPLY	ROADS/PARTS- 418	234.38
ARROWHEAD SCIENTIFIC INC	SUPPLIES - SHERIFF	197.33
AVOCA BUILDING MATERIAL CENTER INC	ROADS/SUPPLIES	14.99
B&R STORES INC	SUPPLIES - SWI JUV	79.17
BEL USA LLC	PROF SVC - CONSERVATION	1,255.50
BERNIE BOLTON	MEETING - BOARD	40.00
BETTY SMITH	LANDSCAPING - WEST POTT SWCD	450.00
BILLS WATER CONDITIONING INC	MO BILL - JAIL	623.80
BISHOP BUSINESS EQUIPMENT COMPANY	PROF SVC - PUBLIC HEALTH	276.95
BLACK HILLS ENERGY	MO BILL - JAIL	7,357.53
BLUFFS ELECTRIC INC	ROADS/PROJECT	6,625.00
BLUFFS TOWERS LP	RENT ASSIST - GA	75.00
BOB BARKER COMPANY INC	SUPPLIES - JAIL	986.71
BOMGAARS SUPPLY INC	SUPPLIES - B&G	1,508.72
BOND COUNTY (IL)	SVC FEES - BOARD	44.00
BOOT BARN HOLDINGS	ROADS/PPE	875.29
BOULDER COUNTY (CO)	SVC FEES - BOARD	41.16
BP ENTERPRISES	PROF SVC - SHERIFF	673.91
BRANDON ALLEN	REIMB EXP - SHERIFF	74.88
BREDA TELEPHONE CORPORATION	MO BILL - COMMUNICATIONS	734.00
BRENDA DAU	MEETING - BOARD	40.00
BRENDA WINDMULLER	MEETING - BOARD	40.00
BRETT LARSON	MEETING - PLANNING	30.04
BRIAN MILLER	REIMB EXP - SHERIFF	261.04
BRIAN MCMILLIN	PROF SVC - BOARD	4,100.00
BROADLAWNS MEDICAL CENTER	MED SVCS - SWIA MHDS REGION	33,120.00
BRUMLEY SUPPLIES LLC	ROADS/SUPPLIES - CENTRAL	7,222.93
BUSINESS CLEANING SOLUTIONS INC	MO BILL - CONSERVATION	517.00
C & J INDUSTRIAL SUPPLY INC	ROADS/UTILITIES - UNDERWOOD	86.50
CALHOUN COMMUNICATIONS INC	PROF SVC - COMMUNICATIONS	1,292.65
CASINO CAB CO LLC	TRANSPORT - JAIL	54.00
CDW LLC	PROF SVC - NON DEPARTMENTAL	83,050.46
CELLCO PARTNERSHIP	MO BILL - SHERIFF	10,345.30
CENTRAL IOWA DETENTION CENTER	TRANSPORT - SWIA MHDS REGION	490.00
CENTURY LINK COMMUNICATIONS LLC	MO BILL - IT	539.10
CENTURYLINK INC	MO BILL - IT	5,832.65
CHAMPLIN TIRE RECYCLING INC	PROF SVC - ENV HEALTH	564.64
CHASITY KEPHART	REIMB EXP - SWIA MHDS REGION	5.71
CHRISTIAN HOME ASSOCIATION	PROF SVC - DHS	5,936.62
CHS INC	FUEL - EMA	88.54
CIMPRESS USA INCORPORATED	SUPPLIES - VA	598.90
CINTAS CORPORATION NO 2	ROADS/SUPPLIES	98.95
CIOX HEALTH	RECORDS - CO ATTORNEY	310.10
CIT BANK NA	PROF SVC - WIC	175.84
CITIBANK NA	SUPPLIES - DHS	1,034.39
CITIBANK NA	MO BILL - B&G	37.70
CITY OF AVOCA	ROADS/UTILITIES	62.82
CITY OF CARSON	ROADS/UTILITIES	199.83
CITY OF COUNCIL BLUFFS	TRANSPORT - JAIL	570.88
CITY OF COUNCIL BLUFFS	PROF SVC - PUBLIC HEALTH	6,304.57
CITY OF HANCOCK	MO BILL - CONSERVATION	223.82
CITY OF OAKLAND	MO BILL - ENV HEALTH	16.00
CITY OF OMAHA	SPONSORSHIP - BOARD	3,000.00
CITY OF WALNUT	ROADS/UTILITIES	42.00

CLARINDA YOUTH CORP	PROF SVC - DHS	1,446.15
COMMERCIAL FARM INDUSTRIAL TIRE SERVICE INC	ROADS/TIRE REPAIR	301.00
COMMSYS INC	PROF SVC - IT	12,193.75
CONCERNED INC	PROF SVC - SWIA MHDS REGION	1,280.00
CONNECTIONS AREA AGENCY ON AGING INC	PROF SVC - PUBLIC HEALTH	7,500.00
CONNER PSYCHOLOGICAL SERVICES	MED SVCS - COMMUNICATIONS	920.00
CONSTABLE CHARLES KOZIOL INC	SVC FEES - CO ATTORNEY	21.00
CONTRACT PHARMACY SERVICES INC	SUPPLIES - JAIL	3,637.37
COREY LITTLE	REIMB EXP - BOARD	676.50
CORNHUSKER INTERNATIONAL TRUCKS INC	ROADS/PARTS - 350	793.09
CORPORATE TRANSLATION SERVICES INC	PROF SVC - PUBLIC HEALTH	21.77
COUNCIL BLUFFS WATER WORKS	MO BILL - JAIL	4,097.40
COUNTRY CARE CENTER CORP	RCF - SWIA MHDS REGION	46,996.80
COX COMMUNICATIONS	MO BILL - IT	8,421.12
CROSSROADS OF WESTERN IOWA	RENT ASSIST - SWIA MHDS REGION	1,119.67
CROWL PROPERTY MANAGEMENT INC	RENT ASSIST - GA	750.00
CRYSTAL CLEAR WATER INC	MO BILL - RECORDER	42.75
CURTIS FISCHER	DRAINAGE - PONY CREEK - TRUSTEE FEES	290.00
CUSTOM COMFORT INC	ROADS/REPAIR - KEG CRK	143.00
CWE FARMS INC	LANDSCAPING - WEST POTT SWCD	1,860.00
D & D CONSTRUCTION SERVICES INC	PROF SVC - PUBLIC HEALTH	3,325.00
D & P FARMS INC	LANDSCAPING - EAST POTT SWCD	785.00
D DAVID CASSON	MEETING - BOARD	40.00
DANA PARTNERSHIP LLP	REFUND - ENV HEALTH	838.00
DANELLE BRUCE	REIMB EXP - SWIA MHDS REGION	109.76
DARIN HAAKE	MEETING - SWI JUV	57.12
DARRELL STAMP	MEETING - BOARD	60.00
DAVES PLACE LLC	MED SVCS - SWIA MHDS REGION	8,400.00
DAVID A MUELL	MEETING - BOARD	100.00
DAVID DAU	MEETING - BOARD	40.00
DAVID K LYON	ROADS/SERVICES- 324	2,729.40
DAVID M LILLEY JR	TRAINING - SHERIFF	500.00
DE LAGE LANDEN FINANCIAL SERVICES INC	PROF SVC - AUDITOR	635.21
DEAF SERVICES UNLIMITED INC	PROF SVC - BOARD	126.00
DEBRA MARTIN	MEETING - BOARD	80.00
DEK CORP	PROF SVC - JAIL	1,408.09
DEL HUSZ	DRAINAGE - PONY CREEK - TRUSTEE FEES	290.00
DELL MARKETING LP	EQUIP - PUBLIC HEALTH	4,400.00
DENISE FISCHER	DRAINAGE - PONY CREEK - CLERK FEES	40.00
DENNIS SUPPLY	SUPPLIES - B&G	395.85
DIANA REINSCH	REIMB EXP - PUBLIC HEALTH	205.71
DIVERSITY FARMS INC	SUPPLIES - CONSERVATION	642.60
DLR GROUP INC	PROF SVC - SHERIFF	2,678.00
DOLORES SILKWORTH	MEETING - PLANNING	40.68
DONALD NIELSON	PUBLICATIONS - BOARD	1,723.87
DONALD NIELSON	PUBLICATIONS - BOARD	1,666.26
DONALD W MATHEWS	PROF SVC - SHERIFF	7,902.03
DONOVAN SIEVERS	LANDSCAPING - EAST POTT SWCD	2,395.40
DOUGLAS COUNTY (NE)	SVC FEES - CO ATTORNEY	142.00
DUSTIN PEREGRINE	REIMB EXP - IT	9.52
DUSTIN SHELDON	MEETING - SWI JUV	54.88
EAST POTT SWCD	REIMB EXP - EAST POTT SWCD	3,000.00
EBS c/o AMERICAN NATIONAL BANK	EBS RETIREES - JAIL	5,649.11
ECHO GROUP INC	EQUIP - PUBLIC HEALTH	36,734.43
EDWARDS MOTORSPORTS	SUPPLIES - CONSERVATION	107.91
ELECTRONIC CONTRACTING COMPANY	PROF SVC - JAIL	1,670.00
ELIOR INC	SUPPLIES - JAIL	49,521.00
EMILY HUGEN	REIMB EXP - EAST POTT SWCD	336.06
ERIC WILSON	RENT ASSIST - GA	400.00
ERRIN KEITH GUNDERSON	PROF SVC - ENV HEALTH	480.00
EUGENE MONIZ	RENT ASSIST - GA	400.00
FARM SERVICE COOPERATIVE	ROADS/FUEL	33,092.05
FARMERS MUTUAL COOPERATIVE TELEPHONE	MO BILL - CONSERVATION	518.09
FASTENAL COMPANY	ROADS/SUPPLIES	223.88
FENN AGRI FARMS	LANDSCAPING - EAST POTT SWCD	2,532.25
FIFTY THIRTEEN CORP	ROADS/HANCOCK FACILITY	5,950.00
FIRESPRING PRINT INC	PROF SVC - CONSERVATION	1,223.40
FIRST NATIONAL BANK OF OMAHA	MO BILL - CONSERVATION	432.80
FMTC SWT INC	ROADS/UTILITIES	130.45
FOCUS FAMILY OPTIONS & COMMUNITY SUPPORTS INC	SUPPORT SVC - SWIA MHDS REGION	1,053.00
FORESTRY SUPPLIERS INC	ROADS/SUPPLIES	519.94
FORRISTCRETE CUSTOM CONCRETE LLC	PROF SVC - CONSERVATION	99,330.00
FOX CREEK FUNDRAISING LLC	PROF SVC - PUBLIC HEALTH	7,060.00
FRANK J BILELLO JR	PROF SVC - JAIL	825.02
FRONTIER COMMUNICATIONS OF IOWA LLC	MO BILL - COMMUNICATIONS	378.29
GALLS LLC	SUPPLIES - SWI JUV	382.00
GARY NILAN	MEETING - BOARD	40.00
GAWLEY TIRE & REPAIR INC	ROADS/TIRES	646.44
GBWH OMAHA LLC	TRAINING - IT	2,370.00
GEE ASPHALT SYSTEMS INC	ROADS/MATERIALS	9,218.19
GENERAL FIRE AND SAFETY EQUIPMENT CO OF OMAHA	PROF SVC - B&G	279.00
GENIE SERVICES	PROF SVC - PUBLIC HEALTH	45.00

GENUINE PARTS COMPANY INC	SUPPLIES - B&G	234.96
GINA HUEBNER	REIMB EXP - SWIA MHDS REGION	71.68
GL DODGE CITY LLC	ROADS/NEW EQUIPMENT - 453	33,876.00
GOVCONNECTION INC	SUPPLIES - IT	161.79
GREAT AMERICA FINANCIAL SERVICES CORPORATION	PROF SVC - RECORDER	452.69
GREAT PLAINS PEST SERVICES INC	PROF SVC - B&G	481.00
GREAT PLAINS UNIFORMS	PROF SVC - SHERIFF	54.50
GREG MATHIS	PROF SVC - WEST POTT SWCD	155.30
GREGORY L DAVIS DDS	MED SVCS - JAIL	1,173.33
GRISWOLD COOPERATIVE TELEPHONE CO	ROADS/UTILITIES	36.02
GRP & ASSOCIATES INC	SUPPLIES - PUBLIC HEALTH	657.88
GUYER MACHINE SHOP INC	ROADS/REPAIR	2,133.04
HAMELE GROUP INC	ROADS/TOOLS	74.07
HANEY SHOE STORE INC	SUPPLIES - JAIL	310.28
HARRISON COUNTY HOMEMAKERS	SUPPORT SVC - SWIA MHDS REGION	536.22
HARRISON COUNTY RURAL ELECTRIC COOPERATIVE	MO BILL - COMMUNICATIONS	436.41
HARRY H WALLAR VIII	PROF SVC - PUBLIC HEALTH	300.00
HAZ-MAT RESPONSE INC	PROF SVC - B&G	17,272.77
HEARTLAND COOP	SUPPLIES - SHERIFF	1,536.83
HEARTLAND FAMILY SERVICE	BRIDGES - SWIA MHDS REGION	81,443.61
HEARTLAND MANAGEMENT DIVISION	RENT - PUBLIC HEALTH	1,530.00
HEARTLAND TIRES AND TREADS INC	ROADS/TIRES	395.20
HENRY SCHEIN INC	SUPPLIES - JAIL	661.26
HGM ASSOCIATES INC	ROADS/HANCOCK	3,970.00
HR AVATAR INC	PROF SVC - JAIL	4,000.00
HUFF TIRE INC	ROADS/TIRES - 444	25.00
HUMAN SERVICES ADVISORY COUNCIL INC	MEMBERSHIP - DHS	100.00
INDOFF	SUPPLIES - TREASURER	1,485.52
INFO USA MARKETING INC	PROF SVC - COMMUNICATIONS	1,215.00
INFOSAFE SHREDDING INC	PROF SVC - DHS	566.00
INSIGHT PUBLIC SECTOR	LICENSE - JAIL	472.59
INTOXIMETERS INC	SUPPLIES - SHERIFF	115.00
IOBP (INSTITUTE OF BUSINESS PUBLICATIONS)	MEMBERSHIP - HR/RISK	265.00
IOWA COMMUNITIES ASSURANCE POOL	INSURANCE - EMA	9,796.00
IOWA DEPARTMENT OF TRANSPORTATION	ROADS/SUPPLIES	7,404.22
IOWA DEPT OF HOMELAND SECURITY & EMERGENCY MANAGEMENT	ROADS/PROJECT	92,664.15
IOWA NATURAL HERITAGE FOUNDATION	MEMBERSHIP - CONSERVATION	400.00
IOWA PLAINS SIGNING INC	PROF SVC - NON DEPARTMENTAL	203,733.00
IOWA STATE ASSOCIATION OF COUNTIES	REGISTRATION - AUDITOR	300.00
IOWA STATE PUBLIC HEALTH	REGISTRATION - SHERIFF	90.00
IOWA WASTE SERVICES HOLDING INC	PROF SVC - JAIL	2,421.26
IOWA WASTE SERVICES HOLDINGS INC	PROF SVC - ENV HEALTH	865.05
IVAN DELGADO MD	MED SVCS - JAIL	3,291.77
J & R DOOR CO	PROF SVC - JAIL	1,280.00
J P COOKE CO	SUPPLIES - ANIMAL CONTROL	95.90
JACKSON SERVICES INC	PROF SVC - B&G	486.78
JAMES E TERRY	ROADS/SERVICES	150.00
JDW MIDWEST LLC	PROF SVC - PLANNING	600.00
JEFFREY J BUCKINGHAM	LANDSCAPING - EAST POTT SWCD	1,068.75
JEFFREY W ANDERSEN	ROADS/TIRES	2,560.49
JEFFS WASH & GLO	PROF SVC - SHERIFF	335.00
JENSEN BUILDERS LTD	ROADS/HANCOCK PROJECT	534,684.15
JEREDITH BRANDS LLC	PROF SVC - B&G/PUBLIC HEALTH	21,409.79
JERICO PROPERTIES LLC	RENT ASSIST - SWIA MHDS REGION	29.00
JIM HAWK TRUCK TRAILERS INC	PROF SVC - PUBLIC HEALTH	663.62
JKL ENTERPRISES INC	PROF SVC - SWIA MHDS REGION	34.66
JOANN PALUBECKI ESTATE	WELL CLOSURE - EAST POTT SWCD	400.00
JODI VANDERHEIDEN	TRANSCRIPTS - CO ATTORNEY	19.50
JODIE BECKMAN	REIMB EXP - AUDITOR	10.08
JOHN DEERE FINANCIAL	ROADS/PARTS - 500	1,107.15
JOHN W GASPARINI INC	SUPPLIES - JAIL	2,076.95
JON THOMAS MD	MED SVCS - JAIL	6,973.55
JONES AUTOMOTIVE INC	PROF SVC - SHERIFF	11,033.54
JP BORING CO	PROF SVC - ENV HEALTH	2,926.20
JP LUMBER INC	ROADS/SUPPLIES	161.95
JUSTIN SCHULTZ	REIMB EXP - BOARD	139.74
KAE FARMS INC	LANDSCAPING - WEST POTT SWCD	1,860.00
KAMBY ENTERPRISES LLC	POSTAGE - CONSERVATION	35.28
KCCC FARMS LLC	LANDSCAPING - WEST POTT SWCD	9,300.00
KELLIE NEWELL	REIMB EXP - IT	3.92
KELLY GREER	REIMB EXP - IT	59.36
KENT SIEVERS	LANDSCAPING - EAST POTT SWCD	3,457.65
KERRI WEDE	MEETING - PLANNING	45.16
KERRY NORTHWAY	PROF SVC - SHERIFF	522.50
KODY WOHLERS	REIMB EXP - CONSERVATION	56.68
KONE INC	PROF SVC - JAIL	286.44
KONICA MINOLTA BUSINESS SOLUTIONS USA INC	PROF SVC - COMMUNICATIONS	245.02
KRISTINA M RICHEY	REIMB EXP - SWIA MHDS REGION	521.36
KRONOS INC	PROF SVC - IT	1,169.20
LANGUAGE LINE SERVICE INC	PROF SVC - COMMUNICATIONS	154.93
LARSEN SUPPLY CO	SUPPLIES - JAIL	3,359.58
LAURA ANDERSEN	TRANSCRIPTS - CO ATTORNEY	111.00

LAWSON PRODUCTS INC	ROADS/SUPPLIES	364.18
LEADS ONLINE LLC	PROF SVC - SHERIFF	3,388.00
LEE BHM CORP	PUBLICATIONS - BOARD	4,205.87
LEWIS HOUSER	LANDSCAPING - EAST POTT SWCD	5,134.00
LINDA SABARTINELLI	RENT ASSIST - GA	500.00
LOCK CRAFTERS LLC	PROF SVC - SWI JUV	198.50
LOESS HILLS OXFORD HOUSE	RENT ASSIST - GA	500.00
LOESS TRAILS FARMS INC	LANDSCAPING - EAST POTT SWCD	8,005.00
LOIS FLEMING	LANDSCAPING - EAST POTT SWCD	3,009.38
LYMAN RICHEY CORPORATION	ROADS/MATERIALS	5,848.40
LYNN GROBE	REIMB EXP - BOARD	493.78
LYNN LEADERS	MEETING - PLANNING	37.32
MAHONEY FIRE SPRINKLER INC	PROF SVC - B&G	760.00
MAIL SERVICES	PROF SVC - TREASURER	2,947.71
MARCO HOLDINGS LLC	PROF SVC - SWIA MHDS REGION	184.06
MARCO TECHNOLOGIES LLC	PROF SVC - SWI JUV	199.00
MARILYN KENNEDY	REIMB EXP - AUDITOR	62.83
MARK MERTES	ROADS/REPAIR	74.25
MARVCO ENTERPRISES INC	EQUIP - COMMUNICATIONS	92.04
MARVEL THIEL	RENT ASSIST - GA	475.00
MATHESON TRI GAS INC	ROADS/SUPPLIES	94.23
MATTHEW REEVES	REIMB EXP - IT	25.20
MCKESSON MEDICAL SURGICAL INC	SUPPLIES - PUBLIC HEALTH	56.36
MEDLINE INDUSTRIES INC	SUPPLIES - PUBLIC HEALTH	82.86
MENARDS	ROADS/SUPPLIES	7,502.96
MERCY HOUSING INC	RENT ASSIST - GA	632.00
METAL CULVERTS INC	ROADS/MATERIALS	9,171.20
MICHAEL ENEWOLD	DRAINAGE - PONY CREEK - TRUSTEE FEES	250.00
MICHAEL J OLSON	MEETING - SWI JUV	109.76
MICHAEL M SALES	PROF SVC - SHERIFF	780.00
MICHAEL TODD & COMPANY	ROADS/SUPPLIES	715.72
MIDAMERICAN ENERGY	MO BILL - B&G	26,642.95
MIDLANDS HUMANE SOCIETY	CONTRACT - ANIMAL CONTROL	7,121.63
MIDWEST GLASS & GLAZING INC	PROF SVC - B&G	1,307.00
MIDWEST MEDICAL AND SAFETY INC	SUPPLIES - AUDITOR	134.55
MIDWEST SERVICE AND SALES CO	ROADS/MATERIALS	39,909.20
MILLS COUNTY (IA)	SVC FEES - CO ATTORNEY	30.00
MINNEHAHA COUNTY (SD)	SVC FEES - BOARD	124.50
MMB LLC	SUPPLIES - CONSERVATION	236.70
MMB LLC	ROADS/PARTS	797.36
MMIS HOLDINGS LLC	DRAINAGE - 2019 FLOOD - VANMAN - CONST/MAINT	194,813.10
MOBILE MINI INC	RENT - PUBLIC HEALTH	739.79
MONOPRICE INC	SUPPLIES - IT	42.60
MOSAIC	PROF SVC - SWIA MHDS REGION	7,460.40
MUNICIPAL HOUSING AGENCY	RENT ASSIST - GA	100.00
NATIONAL SHERIFFS ASSOCIATION	MEMBERSHIP - SHERIFF	135.00
NCH CORPORATION	PROF SVC - B&G	2,220.23
NEBRASKA MACHINERY COMPANY	ROADS/SERVICE - 105	10,817.11
NEBRASKA PEDIATRIC PRACTICE INC	TESTIMONY - CO ATTORNEY	637.19
NEWMAN SIGNS INC	ROADS/MATERIALS	1,804.86
NISHNA PRODUCTIONS INC	PROF SVC - SWIA MHDS REGION	14,137.31
NISHNABOTNA VALLEY RURAL ELECTRIC	ROADS/UTILITIES	3,163.58
OFFICE DEPOT INC	SUPPLIES - CONSERVATION	36.98
OFFICE PRODUCTS CENTER INC	SUPPLIES - CONSERVATION	4,678.60
OHALLORAN INTERNATIONAL INC	ROADS/PARTS	1,154.77
OLD HWY 6 TRACTOR & EQUIPMENT	ROADS/SUPPLIES	564.61
OMAHA COMPOUND	SUPPLIES - JAIL	2,817.05
OMAHA COUNCIL BLUFFS METROPOLITAN AREA PLANNING AGENCY	PROF SVC - BOARD	2,666.80
OMAHA COUNCIL BLUFFS PLUMBING INC	PROF SVC - JAIL	342.50
OMAHA DOOR & WINDOW CO INC	PROF SVC - JAIL	216.13
OMAHA PUBLIC POWER DISTRICT	UTILITY ASSIST - GA	66.68
OMAHA SLINGS INC	ROADS/PARTS	222.16
OMAHA TRUCK CENTER COMPANY INC	ROADS/REPAIR - 376	29,943.17
OMNI CENTRE LLC	RENT - WIC	1,983.00
OTIS ELEVATOR COMPANY	PROF SVC - B&G	8,857.00
OUTDOOR POWER GROUP INC	ROADS/PARTS	427.01
PALUBECKI FAMILY TRUST	WELL CLOSURE - EAST POTT SWCD	400.00
PARALLEL TECHNOLOGIES INC	PROF SVC - NON DEPARTMENTAL	70,000.00
PARTNERSHIP FOR PROGRESS INC	RCF - SWIA MHDS REGION	43,725.50
PATRICK RIGG	RENT ASSIST - GA	900.00
PAUL DAVIS RESTORATION	PROF SVC - B&G	4,891.82
PAUL FORNEY	REIMB EXP - CO ATTORNEY	357.00
PAUL LEES	MEETING - BOARD	60.00
PAUL THIES	ROADS/UTILITIES - CARSON	358.70
PAYLESS OFFICE PRODUCTS	SUPPLIES - BOARD/COMMUNITY SVCS	100,819.16
PETERS LAW FIRM PC	RENT - DHS	2,115.40
PHILLIP MCMARTIN	MEETING - BOARD	40.00
PLATTSMOUTH COUNTY (NE)	SVC FEES - BOARD	62.60
POPCO INC	MO BILL - PLANNING	79.25
POTTAWATTAMIE COUNTY BOARD OF SUPERVISORS	REIMB PHONE - SWIA MHDS REGION	101.47
POTTAWATTAMIE ARTS/CULTURE ENTERTAINMENT (PACE)	CAPITAL CAMPAIGN - BOARD	25,000.00
POTTAWATTAMIE COUNTY CONSERVATION BOARD	PROCESSING FEES - CONSERVATION	347.77

POTTAWATTAMIE COUNTY SHERIFF	DISTRICT COURT SVC FEES - BOARD	2,875.00
PRIDE GROUP INC (THE)	RCF - SWIA MHDS REGION	12,550.04
PROCESS MEASUREMENT COMPANY	ROADS/REPAIRS	174.26
QUADIENT INC	POSTAGE - VARIOUS	5,324.13
QUADIENT LEASING USA INC	PROF SVC - BOARD	1,553.19
R & S WASTE SYSTEMS LLC	ROADS/UTILITIES	637.18
RAFAEL RODRIGUEZ	REIMB EXP - IT	8.12
RAMSEY COUNTY (MN)	SVC FEES - BOARD	70.00
RANDALL PATRICK RING	PROF SVC - CONSERVATION	2,960.00
RANDY THOMPSON	REIMB EXP - IT	2.35
RAY MARTIN COMPANY OF OMAHA	PROF SVC - NON DEPARTMENTAL	76,175.61
RDG IA INC	PROF SVC - NON DEPARTMENTAL	21,533.37
RED OAK WELDING SUPPLIES INC	ROADS/SUPPLIES	501.95
REGIONAL WATER INC	MO BILL - CONSERVATION	1,150.30
REX SIEVERS	MEETING - BOARD	80.00
RICOH USA INC	PROF SVC - VA	126.55
RIVERBEND APARTMENTS LLC	RENT ASSIST - GA	1,120.00
RLKM INC	PROF SVC - SHERIFF	890.60
ROADBUILDERS MACHINERY AND SUPPLY CO INC	ROADS/REPAIR	939.24
ROBERT HOLST	MEETING - BOARD	100.00
ROBERT L WATSON	RENT ASSIST - GA	1,000.00
ROBERT M MCCALL JR	PROF SVC - B&G	8,340.00
RONCO CONSTRUCTION COMPANY INC	PROF SVC - BOARD	282,998.24
RUD CHAIN INC	ROADS/PARTS	3,701.66
S & L ENTERPRISES INC	MO BILL - CONSERVATION	130.00
SAFETY & HEALTH COUNCIL OF GREATER OMAHA INC	ROADS/REGISTRATION	129.00
SAFEWARE INC	EQUIP - EMA	45,157.68
SAM ASHER COMPUTING SERVICES INC	MO BILL - IT	340.77
SAPP BROS PETROLEUM INC	FUEL - SHERIFF	8,479.45
SARPY COUNTY (NE)	SVC FEES - BOARD	37.60
SCHEMMER ASSOCIATES INC (THE)	ROADS/HANCOCK	2,120.25
SCHILDBERG CONSTRUCTION CO INC	ROADS/ROCK	35,355.78
SCHROER & ASSOCIATES PC	PROF SVC - JAIL	180.00
SCOTT BELT	REIMB EXP - BOARD	92.00
SDJD BROWN INC	PROF SVC - SHERIFF	1,856.65
SEIDL & SEIDL PLC	LEGAL SVC - SWIA MHDS REGION	207.00
SHELLEY WELTER	REIMB EXP - SWIA MHDS REGION	268.80
SHIVE HATTERY INC	PROF SVC - CONSERVATION	10,450.00
SHRED IT US JV LLC	PROF SVC - WIC	105.41
SIOUX CITY FOUNDRY COMPANY	ROADS/SUPPLIES	4,585.76
SIOUX COUNTY (IA)	MH ADVOCATE - SWIA MHDS REGION	58.06
SMART WAVE TECHNOLOGIES LLC	PROF SVC - IT	420.00
SOUTHWEST IOWA PLANNING COUNCIL	PROF SVC - PUBLIC HEALTH	4,268.71
SPEEDEE DELIVERY SERVICE INC	PROF SVC - DHS	306.95
ST LUKES HEALTH RESOURCES	ROADS/DRUG SCREENING	42.00
STAPLES INC	SUPPLIES - DHS	2,499.08
STATE UNIVERSITY OF IOWA	PROF SVC - ENV HEALTH	402.50
STEVE BAIER	MEETING - SWI JUV	56.00
SUNDQUIST ENGINEERING PC	DRAINAGE - 2019 FLOOD - SOUTH NOBLE - PROF SVCS	1,154.50
SUNSHINE HOMES INC	RCF - SWIA MHDS REGION	4,867.31
SYMPHONY DIAGNOSTIC SERVICES NO 1	MED SVCS - JAIL	67.00
SYNCHRONY BANK	MO BILL - DHS	24.67
SYNCHRONY BANK	SUPPLIES - CONSERVATION	1,059.67
THERMO KING CHRISTENSEN	ROADS/SUPPLIES	820.00
TORYANN CROZIER	PROF SVC - CONSERVATION	85.00
TRACY CLEVELAND	PROF SVC - ENV HEALTH	124.30
TRANSUNION RISK AND ALTERNATIVE DATA SOLUTIONS INC	PROF SVC - SHERIFF	100.60
TREAT AMERICA FOOD SERVICES	PROF SVC - SWI JUV	3,393.45
TRICIA JONES	MED SVCS - SWI JUV	220.00
TRITECH SOFTWARE SYSTEMS	PROF SVC - IT	135,560.94
TW VENDING INC	SUPPLIES - JAIL	620.94
ULINE INC	SUPPLIES - SHERIFF	919.01
UNDERWOOD FARM SUPPLY LLC	SUPPLIES - CONSERVATION	1,151.60
UNITED CHURCH OF AVOCA	RENT - WIC	50.00
UNITED STATES POSTAL SERVICE	PERMIT - AUDITOR	1,151.00
US BANK NATIONAL ASSOCIATION	MO BILL - IT/GIS	7,780.74
US BANK NATIONAL ASSOCIATION	MO BILL - PLANNING/CONSERVATION	1,108.10
US BANK NATIONAL ASSOCIATION	PROF SVC - SHERIFF	202.94
US CELLULAR	MO BILL - COMMUNICATIONS	549.36
US POSTAL SERVICE (QUADIENT)	POSTAGE - SHERIFF	25,000.00
US VENTURE HOLDINGS INC	SUPPLIES - SHERIFF	177.56
VIRTRU CORPORATION	PROF SVC - IT	2,375.00
VISUAL EDGE INC	PROF SVC - AUDITOR	561.62
VOCATIONAL DEVELOPMENT CENTER INC	PROF SVC - SWIA MHDS REGION	567.00
VOLANO SOFTWARE LLC	PROF SVC - NON DEPARTMENTAL	11,445.00
W W GRAINGER INC	ROADS/SUPPLIES	404.56
WALKERS FIRST AVENUE INC	PROF SVC - SHERIFF	32.75
WALNUT TELEPHONE COMPANY INC	MO BILL - COMMUNICATIONS	776.82
WAUBONSIE MENTAL HEALTH CENTER INC	CSRS/TLP - SWIA MHDS REGION	36,563.80
WEI KAY ENG	REIMB EXP - WIC	28.63
WELLS FARGO FINANCIAL LEASING INC	PROF SVC - DHS	1,288.89
WEST POTT SOIL CONSERVATION	REIMB EXP - WEST POTT SWCD	13,500.00

WEST PUBLISHING CORPORATION
 WESTERN ENGINEERING COMPANY INC
 WESTERN IOWA DEVELOPMENT ASSOCIATION
 WESTLAKE HARDWARE INC
 WEX BANK
 WINDSTREAM
 WINGS REPAIR & TOWING INC
 WOODS & WYATT PLLC
 YLONDA MAGUIRE

PROF SVC - CO ATTORNEY	8,388.86
ROADS/MATERIALS	16,890.80
DUES - BOARD	15,000.00
SUPPLIES - CONSERVATION	680.70
ROADS/FUEL	23,405.46
MO BILL - SHERIFF	64.82
PROF SVC - SHERIFF	187.25
DRAINAGE - PONY CREEK - ATTORNEY FEES	800.00
REIMB EXP - SWIA MHDS REGION	90.72
	<u>3,357,694.14</u>

Fund Summary	Payment Amount
Fund	
0001 - GENERAL BASIC FUND	732,113.71
0002 - GENERAL SUPPLEMENTAL FUND	57,332.78
0003 - GAMBLING RESOURCES FUND	43,302.02
0005 - WIC/FEDERAL FUNDING FUND	3,685.47
0007 - LOST CONSERVATION FUND	17,577.70
0011 - RURAL SERVICES BASIC FUND	20,569.62
0018 - SPECIAL LAW ENFORCEMENT FUND	2,678.00
0019 - PROPERTY ACQUISITION & IMPROVEMENT FUND	282,998.24
0020 - SECONDARY ROADS FUND	470,650.72
0027 - CO CONSERV LAND ACQ	101,573.86
0036 - LOST SOIL CONS WEST FUND	26,970.00
0037 - LOST SOIL CONS EAST FUND	30,523.49
0040 - C.I.T.I.E.S. FUND	2,666.80
0046 - WEST SWCD/POTT CO STRUCTURES FUN	155.30
1610 - BOND SERIES 2018 CAPITAL FUND	41,970.00
1620 - BOND SERIES 2020A CAPITAL FUND	180,100.66
1700 - BIKE TRAIL FUND	225,266.37
1925 - 2020B ROADS CAPITAL PROJECT FUND	542,754.40
4000 - EMER MANAGEMENT SERVICE FUND	54,743.65
4010 - E911 FUND	6,207.70
4155 - MHDS REGION FUND	304,432.13
5400 - JUVENILE DETENTION	11,653.35
6000 - DRAINAGE	197,768.17
	<u>3,357,694.14</u>

Scheduled Sessions

**Public Hearing & Approval of Resolution
No. 16-2021**

FY 21/22 Max Levy

RESOLUTION NO. 16-2021

A Resolution Approving Pottawattamie County's Property Tax Levy for Fiscal Year Ending June 30, 2022

WHEREAS, the Pottawattamie County Board of Supervisors have has considered the proposed fiscal year ending June 30, 2022 County maximum property tax dollars for the affected levy total; and

WHEREAS, a notice concerning the proposed County maximum property tax dollars was published as required and posted on the Pottawattamie County web site and social media accounts, where applicable; and

WHEREAS, a public hearing concerning the proposed Pottawattamie County maximum property tax dollars was held on March 9, 2021.

NOW, THEREFORE, BE IT RESOLVED by the Pottawattamie County Board of Supervisors that the maximum property tax dollars for the affected tax levies for fiscal year ending June 30, 2022, shall not exceed the following total:

Total maximum levy for affected property tax levies for General Services \$38,925,501; and for Rural Services \$6,354,158.

The maximum property tax dollars requested in the total maximum levy for the affected property tax levies for fiscal year ending June 30, 2022, does represent greater than 102% of the maximum property tax dollars requested for current fiscal year ending June 30, 2021.

Dated this 9th day of March, 2021.

ROLL CALL VOTE

	AYE	NAY	ABSTAIN	ABSENT
_____ Scott Belt, Chairman	<input type="radio"/>	<input type="radio"/>	<input type="radio"/>	<input type="radio"/>
_____ Tim Wichman	<input type="radio"/>	<input type="radio"/>	<input type="radio"/>	<input type="radio"/>
_____ Lynn Grobe	<input type="radio"/>	<input type="radio"/>	<input type="radio"/>	<input type="radio"/>
_____ Justin Schultz	<input type="radio"/>	<input type="radio"/>	<input type="radio"/>	<input type="radio"/>
_____ Brian Shea	<input type="radio"/>	<input type="radio"/>	<input type="radio"/>	<input type="radio"/>

ATTEST: _____
Melvyn Houser, County Auditor

**Jason Slack/Director,
Buildings & Grounds**

**Discussion and/or decision to approve:
CO #4; Contract Update**



AIA Document G701™ – 2017

Change Order

PROJECT: <i>(Name and address)</i> Pottawattamie County, Iowa Courthouse Renovation 227 South 6th Street Council Bluffs, IA.	CONTRACT INFORMATION: Contract For: General Construction Date: June 23, 2020	CHANGE ORDER INFORMATION: Change Order Number: 004 Date: February 25, 2021
OWNER: <i>(Name and address)</i> Pottawattamie County Board of Supervisors 227 South 6th Street Council Bluffs, IA.	ARCHITECT: <i>(Name and address)</i> HGM Associates Inc. 640 Fifth Avenue Council Bluffs, Iowa 51501	CONTRACTOR: <i>(Name and address)</i> Ronco Construction Company Inc. 30

THE CONTRACT IS CHANGED AS FOLLOWS:

(Insert a detailed description of the change and, if applicable, attach or reference specific exhibits. Also include agreed upon adjustments attributable to executed Construction Change Directives.)

30	RFI 107 Add Plaster to Exist Vestibule 2nd Flr	471.24
31	Alternate Clean Agent Fire System	\$ (4,590.00)
34	Boiler Room FS and HVAC Clash	\$ 1,595.79
40	ASI #027 Garage Sally Port 030 Window Security	\$ 1,660.05

The original Contract Sum was	\$	<u>5,165,000.00</u>
The net change by previously authorized Change Orders	\$	<u>31,017.30</u>
The Contract Sum prior to this Change Order was	\$	<u>5,196,017.30</u>
The Contract Sum will be decreased by this Change Order in the amount of	\$	<u>862.92</u>
The new Contract Sum including this Change Order will be	\$	<u>5,195,154.38</u>

The Contract Time will be increased by Zero (0) days.
The new date of Substantial Completion will be

NOTE: This Change Order does not include adjustments to the Contract Sum or Guaranteed Maximum Price, or the Contract Time, that have been authorized by Construction Change Directive until the cost and time have been agreed upon by both the Owner and Contractor, in which case a Change Order is executed to supersede the Construction Change Directive.

NOT VALID UNTIL SIGNED BY THE ARCHITECT, CONTRACTOR AND OWNER.

HGM Associates Inc.

ARCHITECT *(Firm name)*

Kimberly A. Bogatz
SIGNATURE

Kimberly A. Bogatz AIA, LEED AP
BD+C

PRINTED NAME AND TITLE

February 25, 2021
DATE

Ronco Construction Company Inc.

CONTRACTOR *(Firm name)*

Nate Bledsoe
SIGNATURE

NATE BLEDSOE, PROJECT MANAGER
PRINTED NAME AND TITLE

FEB 26, 2021
DATE

Pottawattamie County Board of Supervisors

OWNER *(Firm name)*

SIGNATURE

PRINTED NAME AND TITLE

DATE

**Jason Slack/Director,
Buildings & Grounds**

**Discussion and/or decision to approve:
CRC 039 – Add Ground Floor
Conduit**



General Contractor's Cost Summary

PROJECT: Pottawattamie County, Iowa - Courthouse Renovation PROJECT NUMBER: 107419J
 CONTRACTOR: Ronco Construction DATE: 2/10/2021

Contractor's Request for Change (CRC) # and Description: CRC 039 - Add Ground Floor Conduit
 Reference: ASI # and Description: ASI #24 Add Ground Floor Conduit
 RFI # and Description:

Approved Declined

OWNER _____ Date _____

Approved Declined

 _____ 3-3-21
 Kimberly A. Bogatz, AIA Date

NOTE: This form, all Subcontractor/Material Supplier cost summary forms (if appropriate), itemized accountings and appropriate supporting data must be attached to any claim or contractor's request for change proposal for approval.

General Contractor Self Performed Work

- | | | |
|----|---|--|
| 1. | Material supplied by General Contractor..... | |
| 2. | General Contractor's Labor..... | |
| 3. | Equipment | |
| 4. | Subtotal (lines 1, 2 and 3)..... | |
| 5. | Overhead and Profit (15% of line 4)..... | |
| 6. | Total of General Contractor Self Performed Work..... | |

Subcontractor Installation/Work on Site

* (Attach Subcontractor/Supplier Cost Summary Sheet and Summaries/Breakdowns)

- | | | |
|-----|---|--------------------|
| 7. | Subcontractor's cost summary (include but are not limited to the following:) | |
| | a. Mason | |
| | b. Drywaller | |
| | c. Roofer | |
| | d. Flooring | |
| | e. Painter | |
| | f. Plumber | |
| | g. HVAC | |
| | h. Electrician | 19,415.00 |
| | i. Other _____ | |
| | j. Other _____ | |
| | k. Other _____ | |
| | l. Other _____ | |
| | m. Other _____ | |
| 8. | Total Subcontractor's Cost (all lines under 7)..... | \$19,415.00 |
| 9. | General Contractor's Overhead and Profit on Subcontractor's Work (5% of line 8) | \$970.75 |
| 10. | Total of Subcontractor Installation/Work on Site (lines 8 and 9)..... | \$20,385.75 |

CONTRACTOR'S COST SUMMARY

CRC # _____

Project Name: Pottawattamie County, Iowa - Courthouse Renovation

Date: _____

Page 2 of 2

Material Supplier/Subcontractor Providing Materials Manufactured Off Site for General Contractor to Install On Site

*** (Attach Subcontractor/Supplier Cost Summary Sheet and Summaries/Breakdowns)**

- 11. Materials Supplied by Sub or Material Supplier (include but are not limited to the following)
 - a. Structural Steel.....
 - b. Interior Architectural Woodwork.....
 - c. Doors.....
 - d. Windows.....
 - e. Hardware.....
 - f. Other _____
 - g. Other _____
 - h. Other _____
 - i. Other _____
- 12. Subtotal of Materials Supplied.....
- 13. General Contractor's Overhead and Profit (5% of line 12)
- 14. **Total of Materials Supplied by Subcontractor/Material Supplier**
- 15. Material Supplied by General Contractor.....
- 16. General Contractor's Labor.....
- 17. Equipment
- 18. Subtotal (lines 15, 16, and 17).....
- 19. Overhead and Profit (15% of line 18).....
- 20. **Total of General Contractor (lines 18 and 19)**.....

21.	Subtotal (lines 6, 10, 14, and 20)	<u>\$20,385.75</u>
22.	Bond at <u>\$203.86</u> and Insurance at <u>\$203.86</u>	<u>\$407.72</u>
23.	Total Contractors Request for Change (CRC) (lines 21 and 22)	<u>\$20,793.47</u>

February 5, 2021
Ronco Construction
1717 N 74th St.
Omaha, NE 68134
Attention: Nate Bledsoe
RE: ASI 024. (Pottawattamie Co. Courthouse.)

Sir,

Please find enclosed our proposal for the above mentioned project.

This Proposal includes Furnishing and Installing the following:

- 1: (2)-3" conduits from main switchgear to Supply room 026.
- 2: (1)-1 ½" conduit from Emergency panel to Room 026.
- 3: Conduit supports and junction boxes as needed.

Please Note: This proposal EXCLUDES the following:

- 1: Any work not listed above.
- 2: Sales Tax.

Proposal Price: \$19,415.00
(Nineteen Thousand Four Hundred Fifteen Dollars.)

Please call if you have any questions concerning this proposal.
As always thank you for allowing ABC to quote your electrical projects.
Thank you,

Jeff Mohr, Estimator



ARCHITECT'S SUPPLEMENTAL INSTRUCTIONS

Project: Pottawattamie County, Iowa – Courthouse Renovation

HGM Project Number: 107419J

Approved By:

Sent to:

Owner
Architect
Contractor
Field
Other

Owner: Pottawattamie County Board of Supervisors

To Contractor: Ronco Construction Company Inc.

Supplemental Instruction No: **ASI 024 Add Ground Floor Conduit**

Date: **February 04, 2021**

The Work shall be carried out in accordance with the following supplemental instructions issued in accordance with the Contract Documents without change in Contract Time. If there is a change in Contract Time or Cost, submit a Cost Summary on the Architect's Form, along with backup information with any change in contract time, before proceeding with the Work.

DESCRIPTION:

1. Refer to ETI's electrical changes on the attached sheets.

X
Kimberly A. Bogatz, AIA LEED AP BD+C
HGM Associates Inc.

Attachments: E2.0B



DATE ISSUED February 4, 2021

ASI # 24

TO
Ryan TerSteeg
HGM Associates
640 Fifth Avenue
Council Bluffs, Iowa 51502-6427

PROJECT Courthouse Renovation
Pottawattamie County, IA

ETI PROJECT # 2019-142

ASI BY James Minturn

CC Kim Bogatz, Shane Hoss

The work shall be carried out in accordance with the following supplemental instructions issued in accordance with the contract document without change in the contract sum or contract time. Proceeding with the work in accordance with these instructions indicates your acknowledgment that there will be no change in the contract sum or contract time.

General description of modification:

1. Sheet E2.0B – Ground Floor Power Plan – Area B
 - a. Add conduits for future addition power as shown. Provide pull box in Supply 026 and Existing Boiler Room E004 as required.

**Jason Slack/Director,
Buildings & Grounds**

**Discussion and/or decision to approve:
CRC 044 – Boiler Room Kill
Switch Relocation**



General Contractor's Cost Summary

PROJECT: Pottawattamie County, Iowa - Courthouse Renovation PROJECT NUMBER: 107419J
 CONTRACTOR: Ronco Construction DATE: 2/25/2021

Contractor's Request for Change (CRC) # and Description: CRC 044 - Boiler Room Kill Switch
 Reference: ASI # and Description: ASI #018 Boiler Room Kill Switch Location
 RFI # and Description

Approved Declined

OWNER _____ Date _____

Approved Declined

 _____ 3-3-21
 Kimberly A. Bogatz, AIA Date

NOTE: This form, all Subcontractor/Material Supplier cost summary forms (if appropriate), itemized accountings and appropriate supporting data must be attached to any claim or contractor's request for change proposal for approval.

General Contractor Self Performed Work

- | | | |
|----|---|--|
| 1. | Material supplied by General Contractor..... | |
| 2. | General Contractor's Labor..... | |
| 3. | Equipment | |
| 4. | Subtotal (lines 1, 2 and 3)..... | |
| 5. | Overhead and Profit (15% of line 4)..... | |
| 6. | Total of General Contractor Self Performed Work..... | |

Subcontractor Installation/Work on Site

* (Attach Subcontractor/Supplier Cost Summary Sheet and Summaries/Breakdowns)

- | | | |
|-----|---|-----------------|
| 7. | Subcontractor's cost summary (include but are not limited to the following:) | |
| | a. Mason | |
| | b. Drywaller | |
| | c. Roofer | |
| | d. Flooring | |
| | e. Painter | |
| | f. Plumber | |
| | g. HVAC | |
| | h. Electrician | 502.00 |
| | i. Other _____ | |
| | j. Other _____ | |
| | k. Other _____ | |
| | l. Other _____ | |
| | m. Other _____ | |
| 8. | Total Subcontractor's Cost (all lines under 7)..... | \$502.00 |
| 9. | General Contractor's Overhead and Profit on Subcontractor's Work (5% of line 8) | \$25.10 |
| 10. | Total of Subcontractor Installation/Work on Site (lines 8 and 9)..... | \$527.10 |

CONTRACTOR'S COST SUMMARY

CRC # _____

Project Name: Pottawattamie County, Iowa - Courthouse Renovation

Date: _____

Page 2 of 2

Material Supplier/Subcontractor Providing Materials Manufactured Off Site for General Contractor to Install On Site

*** (Attach Subcontractor/Supplier Cost Summary Sheet and Summaries/Breakdowns)**

- 11. Materials Supplied by Sub or Material Supplier (include but are not limited to the following)
 - a. Structural Steel.....
 - b. Interior Architectural Woodwork.....
 - c. Doors.....
 - d. Windows.....
 - e. Hardware.....
 - f. Other _____
 - g. Other _____
 - h. Other _____
 - i. Other _____
- 12. Subtotal of Materials Supplied.....
- 13. General Contractor's Overhead and Profit (5% of line 12)
- 14. **Total of Materials Supplied by Subcontractor/Material Supplier**
- 15. Material Supplied by General Contractor.....
- 16. General Contractor's Labor.....
- 17. Equipment
- 18. Subtotal (lines 15, 16, and 17).....
- 19. Overhead and Profit (15% of line 18).....
- 20. **Total of General Contractor (lines 18 and 19)**.....

21.	Subtotal (lines 6, 10, 14, and 20)	\$527.10
22.	Bond at <u> \$5.27 </u> and Insurance at <u> \$5.27 </u>	\$10.54
23.	Total Contractors Request for Change (CRC) (lines 21 and 22)	\$537.64

February 4, 2021
Ronco Construction
1717 N 74th St.
Omaha, NE 68134
Attention: Nate Bledsoe
RE: ASI 018 (Pottawattamie Co. Courthouse.)

Sir,

Please find enclosed our proposal for the above mentioned project.

This Proposal includes the following:

1: Relocate (2) Boiler emergency shutdown switches to Hall outside Boiler room.

Please Note: This proposal EXCLUDES the following:

1: Any work not listed above.

2: Sales Tax.

Proposal Price: \$502.00
(Five Hundred Two Dollars.)

Please call if you have any questions concerning this proposal.

As always thank you for allowing ABC to quote your electrical projects.

Thank you,

Jeff Mohr, Estimator

Estimate Report

Estimate: ASI 018
Estimated by: Jeff Mohr
File: ASI 018.bhs

02/04/21 7:40:13 AM

Page 2

Worksheet Location: Sheet1(Sheet 1)

DB #	Ph.	Description	Quantity	Mat.	Cost	U	Tot. Mat.	Lab. Hrs.	U	Tot. Hrs.
	0	POTT CO COURTHOUSE ASI 018								
	0	DATED 2/3/21								
	0	RELOCATE 2 BOILER SHUTDOWN SWITCHES TO HALL OUTSIDE BOILER ROOM								
I 1844	1	EM-3/4 EMT-CONDUIT	30.00	123.31	C	36.99	5.63	C		1.69
I 1864	1	EM-3/4 EMT-90-ELLS	4.00	8.93	E	35.71	0.15	E		0.60
I 1922	1	EM-3/4 COMP COUP C	2.00	161.74	C	3.23	0.00	C		0.00
I 1942	1	EM-3/4 COMP CONN C	4.00	141.80	C	5.67	12.50	C		0.50
I 8188	3	WC-THHN-STRA #12	320.00	192.41	M	61.57	6.56	M		2.10

Regular Worksheet Page

Page Multiplier = 1

Material Multiplier = 1

Labor Multiplier = 1

Phase = 0 : Phase Multiplier = 1

Page is Active.

Raw Material Total = \$143.18

Raw Labor Hours = 4.89 Hours

ABC Electric Inc.

Printout from BHSestimator (c) - BHS, Inc., Bolivar, Missouri, USA

Estimate Report

Estimate: ASI 018
Estimated by: Jeff Mohr
File: ASI 018.bhs

02/04/21 7:40:12 AM

Page 1

Summary Page

Raw Material Cost		\$143.18	
Material Tax	0.0000%	\$0.00	
Material Markup	0.0000%	\$0.00	
Material Total			\$143.18
Labor Cost		\$335.84	
Labor Tax	0.0000%	\$0.00	
Labor Markup	0.0000%	\$0.00	
Labor Total			\$335.84
Job Expense			\$0.00
Job Cost			\$479.02
Overhead:	0.0000%	\$0.00	
SubTotal1:			\$479.02
Profit:	5.0000%	\$23.95	
SubTotal2:			\$502.97

Markup Category	Percent	Dollars	Lck
Special Insurance	0.00	\$0.00	N
Performance Bond	0.00	\$0.00	N
Taxes	0.00	\$0.00	N
Adjustments	0.00	\$0.00	N
Summary Markups Total:		\$0.00	
Quotes/Subcontract Total		\$0.00	

Active Linked Estimates

Estimate Total:	\$502.97
Figure Used:	\$502.00

Labor/Material Ratio = 70: 30
Square Footage Calculations Not Performed



ARCHITECT'S SUPPLEMENTAL INSTRUCTIONS

Project: Pottawattamie County, Iowa – Courthouse Renovation

HGM Project Number: 107419J

Approved By:

Sent to:

Owner
Architect
Contractor
Field
Other

X

Owner: Pottawattamie County Board of Supervisors

To Contractor: Ronco Construction Company Inc.

Supplemental Instruction No: **ASI #018 Boiler Room Kill Switch Location**

Date: **February 03, 2021**

The Work shall be carried out in accordance with the following supplemental instructions issued in accordance with the Contract Documents without change in Contract Time. If there is a change in Contract Time or Cost, submit a Cost Summary on the Architect's Form, along with backup information with any change in contract time, before proceeding with the Work.

DESCRIPTION:

1. Refer to ETI's relocation of the boiler room kill switch on the attached sheets.

X Kimberly Bogatz
Kimberly A. Bogatz, AIA LEED AP BD+C
HGM Associates Inc.

Attachments: M4.1, E2.0B



DATE ISSUED February 2, 2021

ASI # 18

TO
Ryan TerSteeg
HGM Associates
640 Fifth Avenue
Council Bluffs, Iowa 51502-6427

PROJECT Courthouse Renovation
Pottawattamie County, IA

ETI PROJECT # 2019-142

ASI BY Wyatt Wirges

CC Kim Bogatz, Shane Hoss

The work shall be carried out in accordance with the following supplemental instructions issued in accordance with the contract document without change in the contract sum or contract time. Proceeding with the work in accordance with these instructions indicates your acknowledgment that there will be no change in the contract sum or contract time.

General description of modification:

1. Sheet M4.1 – Enlarged Mechanical Plans
 - a. Relocated emergency boiler kill switches from inside room to outside room. Kill switches to be provide with non-locking plastic cover plate over push button.
2. Sheet E2.0B – Ground Floor Power Plan – Area B
 - a. New location for emergency boiler shut off switches.

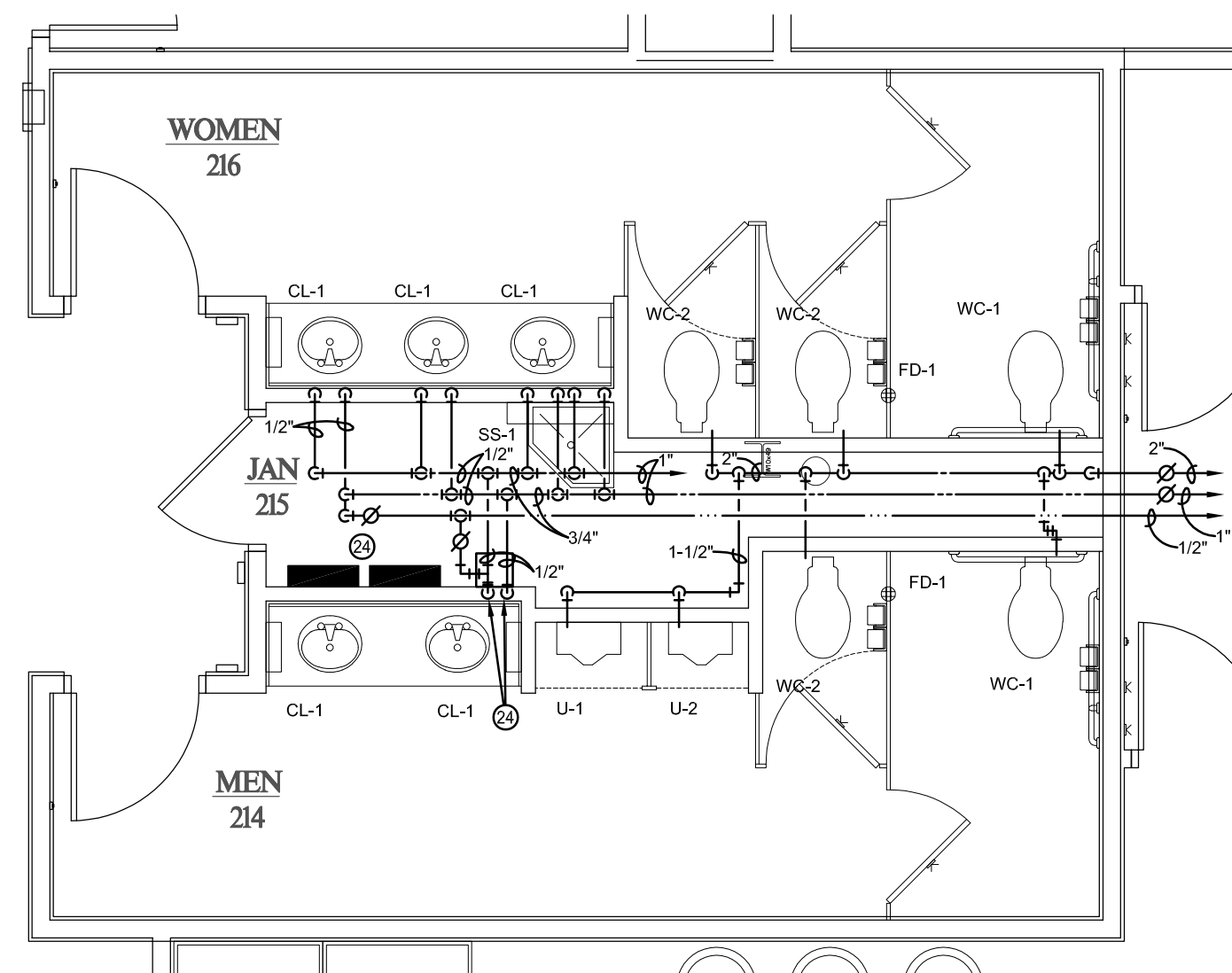

4 ENLARGED SECOND FLOOR RESTROOM PLAN
SCALE: 1/4" = 1'-0"

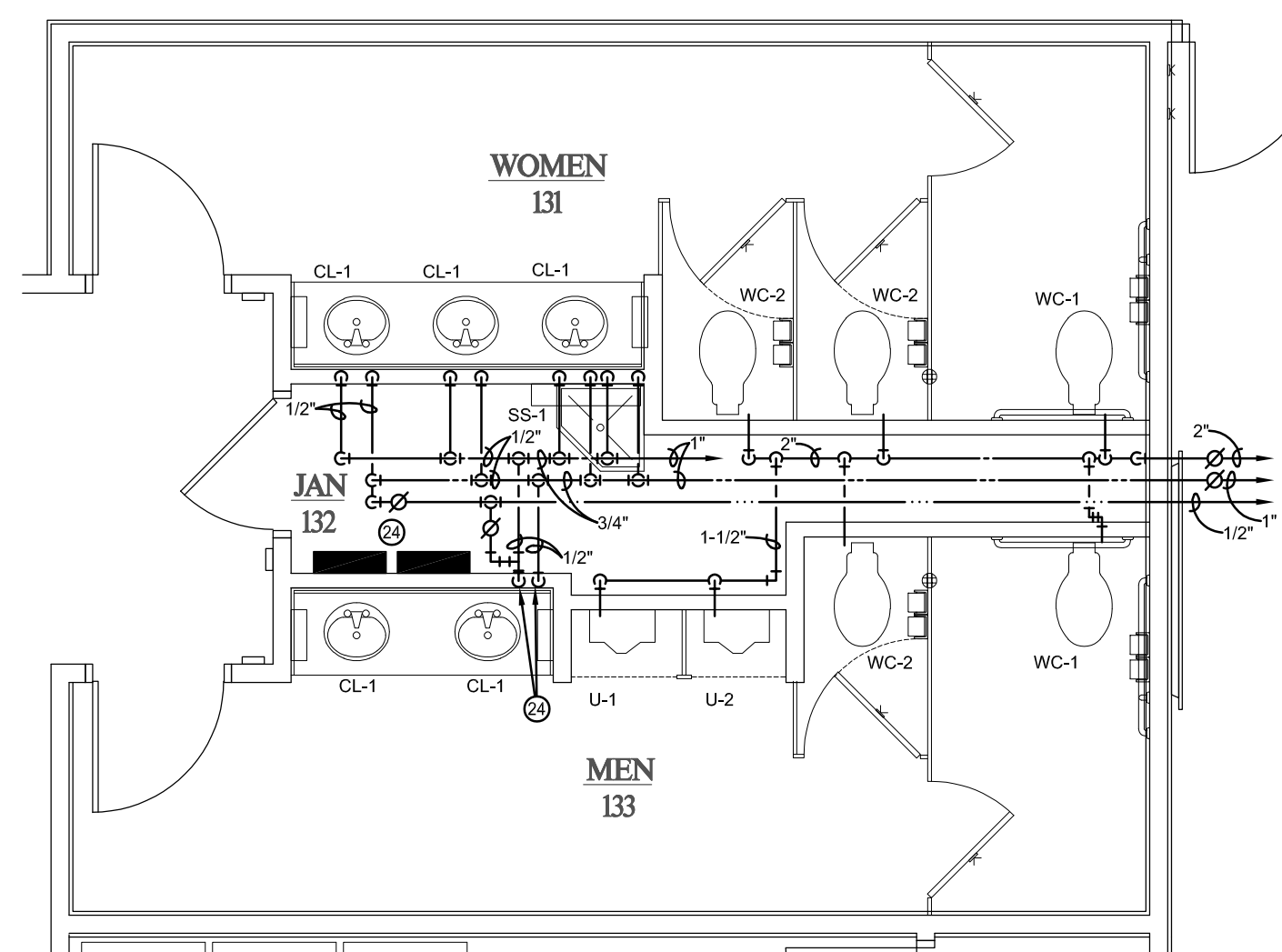

3 ENLARGED FIRST FLOOR RESTROOM PLAN
SCALE: 1/4" = 1'-0"

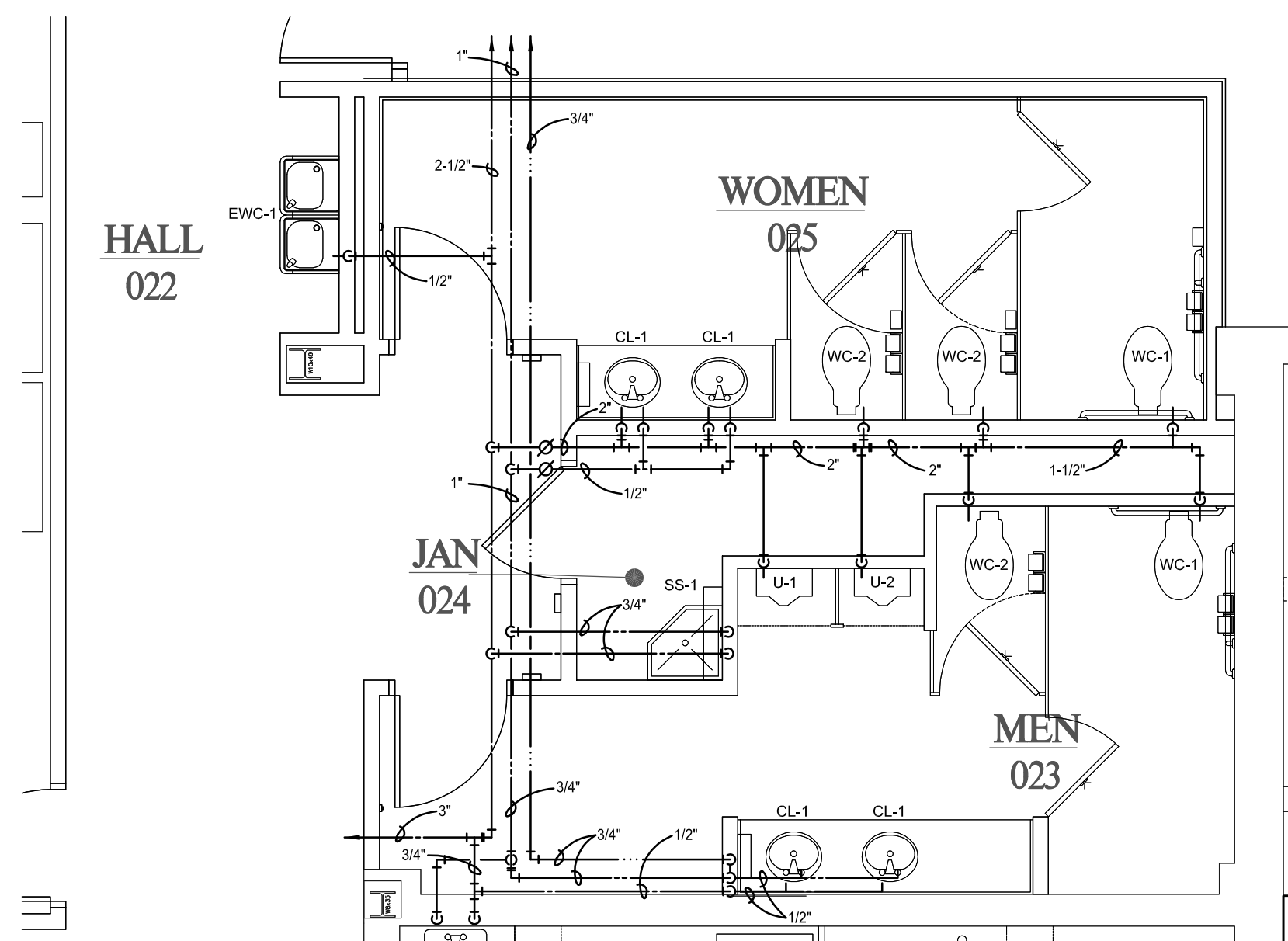

2 ENLARGED GROUND FLOOR RESTROOM PLAN
SCALE: 1/4" = 1'-0"

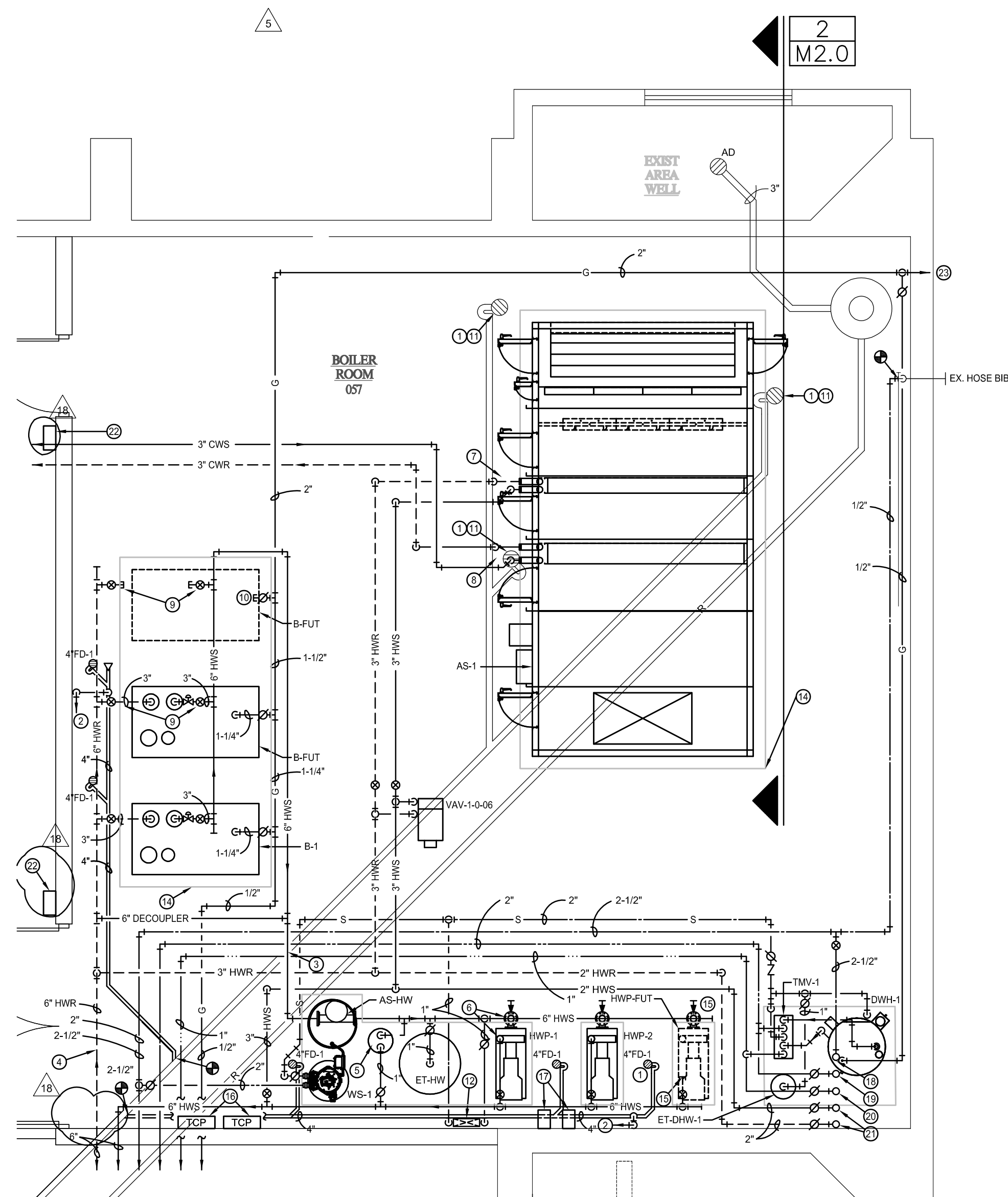

1 ENLARGED BOILER ROOM PLAN
SCALE: 1/4" = 1'-0"



GENERAL NOTES

- A. EXISTING WORK SHOWN WAS OBTAINED USING FIELD VERIFICATION. NOT ALL EQUIPMENT AND DISTRIBUTION SYSTEMS MAY BE SHOWN. CONTRACTOR TO VERIFY ALL SYSTEMS AND EQUIPMENT PRIOR TO COMMENCING WORK. IF A DEVIATION BETWEEN EXISTING CONDITIONS AND NEW WORK IS FOUND, CONTRACTOR TO NOTIFY ENGINEER.
- B. EXISTING SPRINKLER HEADS IN OPEN AREAS SHALL REMAIN AND BE REVISED TO MEET NFPA 13 REQUIREMENTS. SPRINKLER HEADS IN FINISHED AREAS SHALL BE REMOVED, REVISED, OR REPLACED TO MEET NEW FINISH AREA AND NFPA 13 REQUIREMENTS. SPRINKLER HEADS CURRENTLY IN EXPOSED AREAS SHALL BE REMOVED, REVISED, OR REPLACED TO MATCH NEW FINISHED CEILING AREA AS REQUIRED. SEE ARCHITECTURAL PLANS TO COORDINATE ALL CEILING TYPES. VERIFY EXACT LOCATION, SIZE, AND ALL OTHER REQUIREMENTS ON SITE.
- C. CONTRACTOR SHALL MAINTAIN FIRE AND SMOKE RATINGS AT PENETRATIONS THROUGH RATED WALLS. COORDINATE EXACT LOCATIONS WITH ARCHITECTURAL CODE PLAN.
- D. COORDINATE EXACT LOCATION OF ALL PIPING WITH LIGHTS, DUCTWORK, STRUCTURE, AND EQUIPMENT / FIXTURES.
- E. CONTRACTOR SHALL AVOID INSTALLING ANY PIPING ABOVE ELECTRICAL PANELS, DISCONNECTS, OR SWITCHBOARDS.
- F. SUPPORT ALL NEW SUSPENDED HVAC EQUIPMENT FROM EXISTING STRUCTURE WITH "ALL THREAD" HANGING ROD.
- G. PATHWAYS FOR ALL EXPOSED UTILITIES SHALL BE APPROVED BY THE ARCHITECT PRIOR TO INSTALLATION, INCLUDING BUT NOT LIMITED TO: FIRE SPRINKLERS, CONDUITS, DATA RACEWAYS, DUCTS, AND PIPES.
- H. REFER TO THE ARCHITECTURAL DRAWINGS FOR THE LOCATIONS OF RATED WALLS.
- I. FINAL ROUTING AND SIZING OF FLUE AND COMBUSTION AIR DUCT SHALL BE CONFIRMED WITH EQUIPMENT MANUFACTURERS.
- J. PROVIDE SHUT-OFF VALVE IN WATER PIPING AT EASILY ACCESSIBLE LOCATION BEFORE CONNECTION AT EQUIPMENT / FIXTURE.
- K. COORDINATE ALL REQUIRED SAW CUTTING FOR BELOW FLOOR PIPING WITH GENERAL CONTRACTOR. PATCH AND REPAIR FLOORING UPON INSTALLATION COMPLETION AND APPROVED INSPECTION.
- L. COORDINATE WITH, AND ADJUST EXISTING SANITARY SEWER, FIRE SPRINKLER PIPING, AND FIRE MAINS WITHIN BOILER ROOM WITH NEW INSTALLATIONS OF MEP SYSTEMS.
- M. PROVIDE NEOPRENE PAD ISOLATORS UNDER FLOOR MOUNTED EQUIPMENT.

SHEET NOTES

1. PROVIDE MECHANICAL ROOM FLOOR DRAINS WITH TRAP SEALS. TYPICAL.
2. CONNECT 2" VENT TO EXISTING VENT STACK.
3. FLOW METER AND SUPPLY TEMPERATURE SENSOR LOCATION FOR PACKAGED BTU METER. MAINTAIN ALL MANUFACTURER REQUIRED CLEARANCES.
4. RETURN TEMPERATURE SENSOR LOCATION FOR PACKAGE BTU METER.
5. CHEMICAL FEED TANK. PIPE PER DETAIL 6M5.1.
6. 4" HWS/R DOWN TO HEATING WATER PUMP. TYPICAL.
7. 3" HWS/R DOWN TO PRE-HEAT COIL. PIPE PER DETAIL 2M5.2.
8. 3" CWS/R DOWN TO CHILLED WATER COIL. PIPE PER DETAIL 3M5.2.
9. 3" HWS/R VALVED AND CAPPED FOR FUTURE BOILER.
10. 1-1/4" GAS VALVED AND CAPPED FOR FUTURE BOILER.
11. CONTRACTOR SHALL CONFIRM LOCATIONS OF EXISTING FLOOR DRAINS AND COORDINATE WITH NEW EQUIPMENT HOUSEKEEPING PADS. RELOCATE FLOOR DRAINS AS REQUIRED.
12. 1" RPZ FOR HEATING WATER MAKEUP. PROVIDE VALVES AND ACCESSORIES PER 1M7.2. INDIRECT DRAIN TO FLOOR DRAIN.
13. 3" CHILLED WATER SUPPLY AND RETURN PIPING SHALL BE VALVED AND CAPPED FOR FUTURE CONNECTIONS.
14. 4" HOUSEKEEPING PAD. TYPICAL ALL EQUIPMENT.
15. 4" HWS/R VALVED AND CAPPED FOR FUTURE PUMP.
16. TEMPERATURE CONTROL PANEL. TYPICAL.
17. VFDS FOR HWP-1 AND HWP-2. MAINTAIN NEC REQUIRED CLEARANCES.
18. 2-1/2" DOMESTIC COLD WATER UP IN SHAFT.
19. 1" DOMESTIC HOT WATER UP IN SHAFT.
20. 3/4" DOMESTIC HOT WATER RECIRCULATION LINE UP IN SHAFT.
21. 2" HWS/R UP IN SHAFT.
22. EMERGENCY BOILER SHUTDOWN BUTTON INTERLOCKED WITH FUEL BURNING EQUIPMENT IN THE BOILER ROOM.
23. 2" GAS LINE TO NEW METER. REFER TO M1.08 FOR CONTINUATION.
24. 1/2" DOMESTIC HOT AND COLD WATER IN WALL FOR COUNTER LAVATORIES. COORDINATE WITH ELECTRICAL CONTRACTOR AND PANEL LOCATIONS.

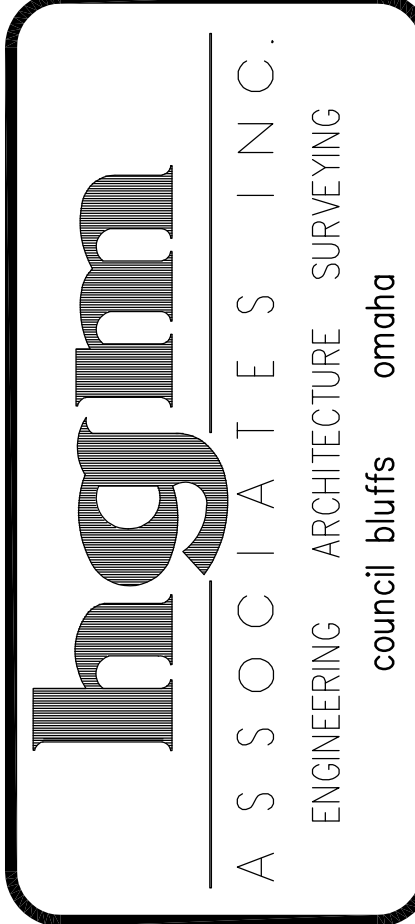
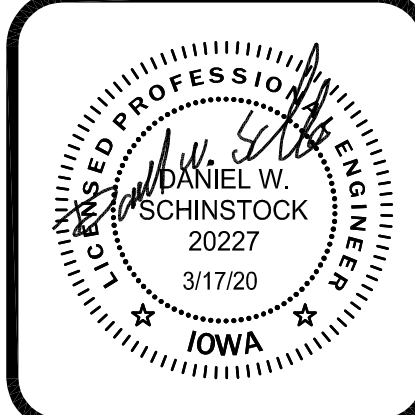

This drawing is being made available for use on this project in accordance with hgm associates inc. agreement with hgm associates inc. regarding the use of this drawing for any part thereof except in accordance with the terms of the above agreement.

CODE	DATE	BY	DATE	BY	DATE	REVISION
drawn	4-17-20					date
checked	4-24-20					revision
designed	4-30-20					
approved	2-2-21					
	JUN 2020					

POTTAWATTAMIE COUNTY, IOWA
COURTHOUSE RENOVATION
227 SOUTH 6TH STREET
COUNCIL BLUFFS, IOWA
POTTAWATTAMIE COUNTY BOARD OF SUPERVISORS

ADDENDUM POSTED SET

project sheet
client sheet

project no.
107419J
sheet
M4.1

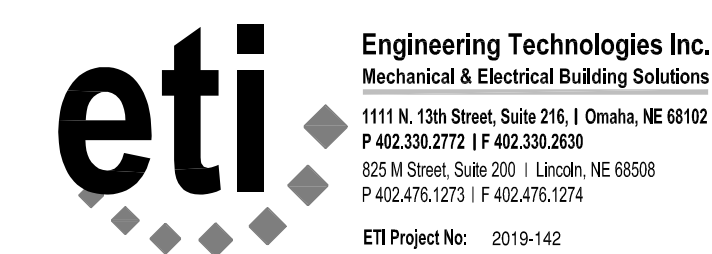

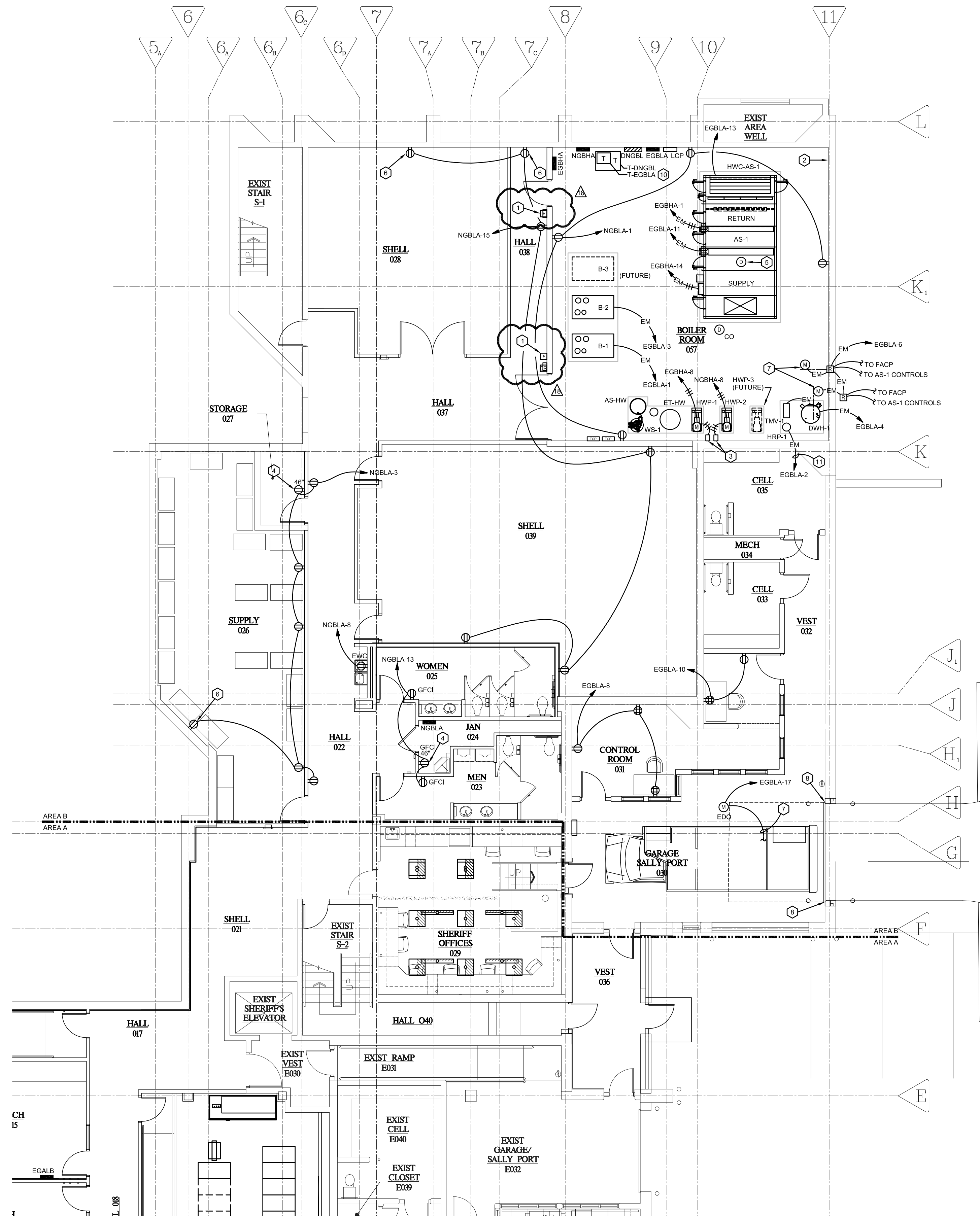

1 GROUND FLOOR POWER PLAN - AREA B
 SCALE: 1/8" = 1'-0"



GENERAL NOTES

- A. PROVIDE TEMPORARY POWER, LIGHTING, AND HEATING AS REQUIRED FOR CONSTRUCTION. COORDINATE WITH THE GENERAL CONTRACTOR AND OTHER TRADES.
- B. FIRE SEAL ALL PENETRATIONS THROUGH FIRE RATED WALLS, CEILING AND FLOORS.
- C. COORDINATE LOCATION OF WIRING DEVICES, TELECOM OUTLETS, FIRE ALARM DEVICES, ETC. WITH MILLWORK, TILE LAYOUT, AND OTHER WALL FINISHES PRIOR TO ROUGH-IN.
- D. ALIGN ADJACENT WALL MOUNTED OUTLET BOXES FOR SWITCHES, THERMOSTATS, AND SIMILAR DEVICES. DEVICES SHALL BE ALIGNED VERTICALLY WHEN INSTALLED AT DIFFERING HEIGHTS AND INSTALL ALL ADJACENT DEVICES AT THE SAME HEIGHT TO CENTER. NOTIFY ARCHITECT OF ANY DISCREPANCIES BETWEEN TRADES PRIOR TO ROUGH-IN.
- E. REFERENCE ARCHITECTURAL PLANS FOR RAISED FLOOR DETAILS.

SHEET NOTES

- 1. BOILER SAFETY SHUTDOWN SWITCH WITH RED MUSHROOM PUSH BUTTON, FOUR(4) NORMALLY OPEN CONTACTS. CONNECT TO BOILER CONTROL CIRCUIT. LABEL SWITCH WITH ENGRAVED NAMEPLATE IN ACCORDANCE WITH BOILER INSPECTOR REQUIREMENTS.
- 2. EXISTING FIBER SERVICE. PROTECT THROUGHOUT CONSTRUCTION AND PROVIDE ADDITIONAL SUPPORTS.
- 3. VFD FURNISHED BY MECHANICAL CONTRACTOR. METER ALL LINE VOLTAGE CONNECTIONS AND COORDINATE INSTALLATION LOCATION TO ENSURE PROPER CLEARANCES ARE MET. (TYPICAL)
- 4. GANG WITH LIGHT SWITCH. PROVIDE VOLTAGE SEPARATOR.
- 5. DUCT MOUNTED SMOKE DETECTOR IN SUPPLY DUCT OF AIR SUPPLY FAN (AS-1). PROVIDE SHUTDOWN RELAY AND CONNECT TO FIRE ALARM SYSTEM AND CONTROL CIRCUIT OF AIR SUPPLY FAN (AS-1).
- 6. APPROXIMATE LOCATION OF ORIGINAL OUTLET. RE-USE FLUSH BOX AND CONDUIT IF AVAILABLE.
- 7. MOTORIZED FIRE AND SMOKE DAMPER (FSD) AND CONTROL RELAY. FIRE AND SMOKE DAMPER SHALL BE POWER OPENING/SPRING CLOSED. RELAY SHALL BE INTERCONNECTED WITH THE FIRE ALARM SYSTEM AND ASSOCIATED HVAC EQUIPMENT SO THAT WHEN THE FIRE ALARM SYSTEM IS ACTIVATED, THE DAMPER SHALL CLOSE AND ASSOCIATED HVAC EQUIPMENT SHALL SHUTDOWN.
- 8. CONNECT TO KEYPADS CONTROLLING GARAGE DOOR.
- 9. PROVIDE 3/4" CONDUIT FOR LOW VOLTAGE WIRING FOR GARAGE DOOR SENSOR.
- 10. WALL MOUNT TRANSFORMER.
- 11. CIRCUIT FOR DOMESTIC HOT WATER RECIRC PUMP. SEE MECHANICAL PLANS.
- 12. MOTORIZED DAMPER FOR GAS DETECTION SYSTEM. PROVIDE RELAY FOR CONTROL INPUT FROM GAS DETECTION PANEL. USE #12 AWG CONDUCTORS THROUGHOUT CIRCUIT.

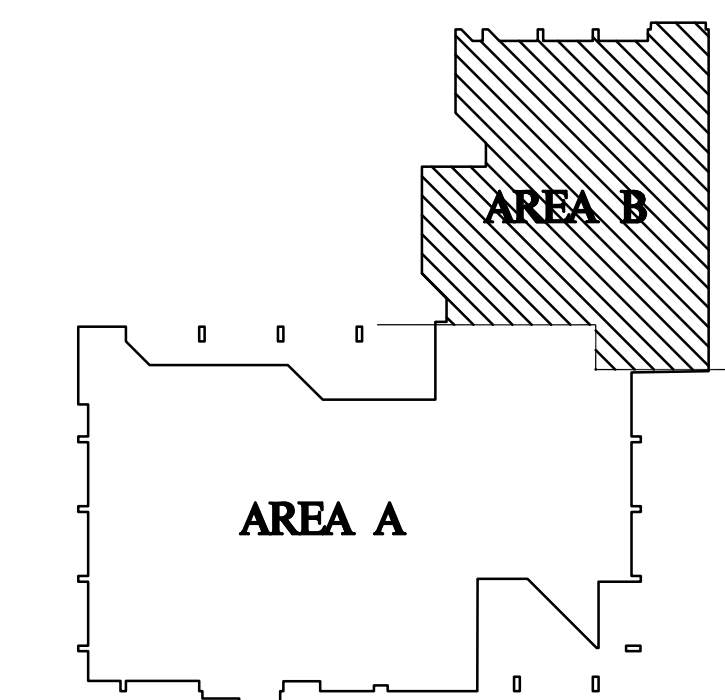

KEY PLAN GROUND FLOOR

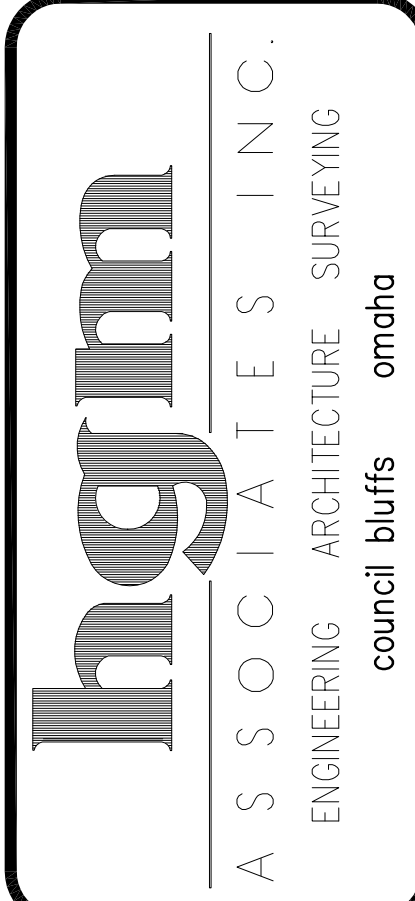
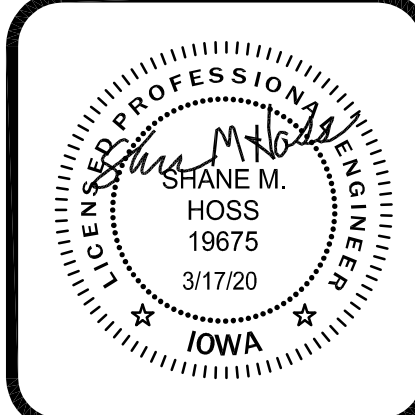

This drawing is being made available for use on this project in accordance with high professional standards. The quality of the work is guaranteed for the use of this drawing or any part thereof except in accordance with the terms of the above agreement.

DATE	REVISION
2-2-21	

POTTAWATTAMIE COUNTY, IOWA
COURTHOUSE RENOVATION
 227 SOUTH 6TH STREET
 COUNCIL BLUFFS, IOWA
 POTTAWATTAMIE COUNTY BOARD OF SUPERVISORS
GND FLR POWER PLAN - AREA B

project no. **107419J**
 sheet **E2.0B**

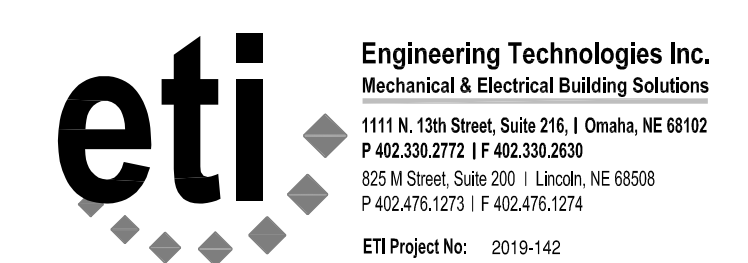

Engineering Technologies Inc.
 Mechanical & Electrical Building Solutions
 1111 N. 13th Street, Suite 210, Omaha, NE 68102
 P 402.330.2772 | F 402.330.2630
 625 M Street, Suite 200 | Lincoln, NE 68508
 P 402.476.1273 | F 402.476.1274
 ETI Project No: 2019-142

**Jason Slack/Director,
Buildings & Grounds**

**Discussion and/or decision to approve:
CRC 045 – Remove Painting of
Ground Floor Ceiling**



General Contractor's Cost Summary

PROJECT: Pottawattamie County, Iowa - Courthouse Renovation PROJECT NUMBER: 107419J
 CONTRACTOR: Ronco Construction DATE: 3/1/2021

Contractor's Request for Change (CRC) # and Description: CRC 045 - Remove Painting of Ground Floor Ceilin
 Reference: ASI # and Description ASI #19 Remove Painting of Ground Floor Ceiling
 RFI # and Description

Approved Declined

OWNER

Date

Approved Declined

 Kimberly A. Bogatz, AIA

3-3-21

Date

NOTE: This form, all Subcontractor/Material Supplier cost summary forms (if appropriate), itemized accountings and appropriate supporting data must be attached to any claim or contractor's request for change proposal for approval.

General Contractor Self Performed Work

- | | | |
|----|---|--|
| 1. | Material supplied by General Contractor..... | |
| 2. | General Contractor's Labor..... | |
| 3. | Equipment | |
| 4. | Subtotal (lines 1, 2 and 3)..... | |
| 5. | Overhead and Profit (15% of line 4)..... | |
| 6. | Total of General Contractor Self Performed Work..... | |

Subcontractor Installation/Work on Site

* (Attach Subcontractor/Supplier Cost Summary Sheet and Summaries/Breakdowns)

- | | | |
|-----|---|--------------------|
| 7. | Subcontractor's cost summary (include but are not limited to the following:) | |
| | a. Mason | |
| | b. Drywaller | |
| | c. Roofer | |
| | d. Flooring | |
| | e. Painter | -1,887.00 |
| | f. Plumber | |
| | g. HVAC | |
| | h. Electrician | |
| | i. Other _____ | |
| | j. Other _____ | |
| | k. Other _____ | |
| | l. Other _____ | |
| | m. Other _____ | |
| 8. | Total Subcontractor's Cost (all lines under 7)..... | -\$1,887.00 |
| 9. | General Contractor's Overhead and Profit on Subcontractor's Work (5% of line 8) | |
| 10. | Total of Subcontractor Installation/Work on Site (lines 8 and 9)..... | -\$1,887.00 |

CONTRACTOR'S COST SUMMARY

CRC # _____

Project Name: Pottawattamie County, Iowa - Courthouse Renovation

Date: _____

Page 2 of 2

Material Supplier/Subcontractor Providing Materials Manufactured Off Site for General Contractor to Install On Site

*** (Attach Subcontractor/Supplier Cost Summary Sheet and Summaries/Breakdowns)**

- 11. Materials Supplied by Sub or Material Supplier (include but are not limited to the following)
 - a. Structural Steel.....
 - b. Interior Architectural Woodwork.....
 - c. Doors.....
 - d. Windows.....
 - e. Hardware.....
 - f. Other _____
 - g. Other _____
 - h. Other _____
 - i. Other _____
- 12. Subtotal of Materials Supplied.....
- 13. General Contractor's Overhead and Profit (5% of line 12)
- 14. **Total of Materials Supplied by Subcontractor/Material Supplier**
- 15. Material Supplied by General Contractor.....
- 16. General Contractor's Labor.....
- 17. Equipment
- 18. Subtotal (lines 15, 16, and 17).....
- 19. Overhead and Profit (15% of line 18).....
- 20. **Total of General Contractor (lines 18 and 19)**.....

21.	Subtotal (lines 6, 10, 14, and 20)	<u>-\$1,887.00</u>
22.	Bond at <u>-\$18.87</u> and Insurance at <u>-\$18.87</u>	<u>-\$37.74</u>
23.	Total Contractors Request for Change (CRC) (lines 21 and 22)	<u>-\$1,924.74</u>

Larsen Painting

15 S 14th Street
Council Bluffs, IA 51501 US
+1 4026591695
larsenmike60@gmail.com

Estimate

ADDRESS
Pottawattamie County Courthouse Renovation

ESTIMATE 1096
DATE 03/01/2021

SERVICE	DESCRIPTION	QTY	RATE	AMOUNT
	Deductions on project.			
Sales	Deduct cost for not painting ceilings in rooms 026, 027, and 057		1,887.00	1,887.00
Sales	Deduct cost for changes in Hallway 040.		218.00	218.00
			TOTAL	\$2,105.00

Accepted By

Accepted Date



ARCHITECT'S SUPPLEMENTAL INSTRUCTIONS

Project: Pottawattamie County, Iowa – Courthouse Renovation

HGM Project Number: 107419J

Approved By:

Sent to:

Owner
Architect
Contractor
Field
Other

X

Owner: Pottawattamie County Board of Supervisors

To Contractor: Ronco Construction Company Inc.

Supplemental Instruction No: **ASI #019 Remove Painting of Ground Floor Ceilings**

Date: **January 11, 2021**

The Work shall be carried out in accordance with the following supplemental instructions issued in accordance with the Contract Documents without change in Contract Time. If there is a change in Contract Time or Cost, submit a Cost Summary on the Architect’s Form, along with backup information with any change in contract time, before proceeding with the Work.

DESCRIPTION:

1. Remove painting the ceilings in Supply 026, Storage 027, and Boiler Room 057 from the scope of work. Provide the owner with a credit.

X

Kimberly A. Bogatz, AIA LEED AP BD+C
HGM Associates Inc.

Attachments: None

**Jason Slack/Director,
Buildings & Grounds**

**Discussion and/or decision to approve:
CRC 046 – Control Room
Changes**



General Contractor's Cost Summary

PROJECT: Pottawattamie County, Iowa - Courthouse Renovation PROJECT NUMBER: 107419J
 CONTRACTOR: Ronco Construction DATE: 3/1/2021

Contractor's Request for Change (CRC) # and Description: CRC 046 - Control Room 031 Layout Changes
 Reference: ASI # and Description: ASI #11 Control Room 031 Layout Changes
 RFI # and Description

<input type="checkbox"/> Approved	<input type="checkbox"/> Declined
<hr/>	
OWNER	Date
<input checked="" type="checkbox"/> Approved	<input type="checkbox"/> Declined
<hr/>	
	3-3-21
Kimberly A. Bogatz, AIA	Date

NOTE: This form, all Subcontractor/Material Supplier cost summary forms (if appropriate), itemized accountings and appropriate supporting data must be attached to any claim or contractor's request for change proposal for approval.

General Contractor Self Performed Work

1.	Material supplied by General Contractor.....		
2.	General Contractor's Labor.....	-\$50.00	
3.	Equipment		
4.	Subtotal (lines 1, 2 and 3).....	-\$50.00	
5.	Overhead and Profit (15% of line 4).....		
6.	Total of General Contractor Self Performed Work.....	-\$50.00	

Subcontractor Installation/Work on Site

* (Attach Subcontractor/Supplier Cost Summary Sheet and Summaries/Breakdowns)

7.	Subcontractor's cost summary (include but are not limited to the following:)		
	a. Mason		
	b. Drywaller		
	c. Roofer		
	d. Flooring		
	e. Painter		
	f. Plumber		
	g. HVAC		
	h. Electrician		
	i. Other: Security Equipment	-3,808.13	
	j. Other		
	k. Other		
	l. Other		
	m. Other		
8.	Total Subcontractor's Cost (all lines under 7).....	-\$3,808.13	
9.	General Contractor's Overhead and Profit on Subcontractor's Work (5% of line 8)		
10.	Total of Subcontractor Installation/Work on Site (lines 8 and 9).....	-\$3,808.13	

CONTRACTOR'S COST SUMMARY

CRC # _____

Project Name: Pottawattamie County, Iowa - Courthouse Renovation

Date: _____

Page 2 of 2

Material Supplier/Subcontractor Providing Materials Manufactured Off Site for General Contractor to Install On Site

*** (Attach Subcontractor/Supplier Cost Summary Sheet and Summaries/Breakdowns)**

11.	Materials Supplied by Sub or Material Supplier (include but are not limited to the following)	
	a. Structural Steel.....	<u>-\$150.00</u>
	b. Interior Architectural Woodwork.....	_____
	c. Doors.....	_____
	d. Windows.....	_____
	e. Hardware.....	_____
	f. Other _____	_____
	g. Other _____	_____
	h. Other _____	_____
	i. Other _____	_____
12.	Subtotal of Materials Supplied.....	<u>-\$150.00</u>
13.	General Contractor's Overhead and Profit (5% of line 12)	_____
14.	Total of Materials Supplied by Subcontractor/Material Supplier	<u>-\$150.00</u>
15.	Material Supplied by General Contractor.....	_____
16.	General Contractor's Labor.....	_____
17.	Equipment	_____
18.	Subtotal (lines 15, 16, and 17).....	_____
19.	Overhead and Profit (15% of line 18).....	_____
20.	Total of General Contractor (lines 18 and 19).....	_____
<hr/>		
21.	Subtotal (lines 6, 10, 14, and 20)	<u>-\$4,008.13</u>
22.	Bond at <u>-\$40.08</u> and Insurance at <u>-\$40.08</u>	<u>-\$80.16</u>
23.	Total Contractors Request for Change (CRC) (lines 21 and 22)	<u>-\$4,088.29</u>

Completing the information on this sheet will populate the other sheets with the basic information.

Project Number	139194
Project Name	Pottawattamie County Courthouse Council Bluffs, IA
Contract Number	139194
Contract Work (Trade)	Bid Package 1
RFP NO.	ASI#11
CONTRACTOR NAME	Jails Correctional Products
ADDRESS	350 South Ohio Street
CITY, STATE, ZIP	Minster, OH 45865
DATE:	10/14/2020

Jails Correctional Products

Contractor's/Subcontractor's
 Proposal Breakdown Summary
 Date: 10/14/2020

FROM: Contractor/Subcontractor Name, Address	Project No. <u>139194</u>
<u>Jails Correctional Products</u>	<u>Pottawattamie County Courthouse</u>
<u>350 South Ohio Street</u>	<u>Council Bluffs, IA</u>
<u>Minster, OH 45865</u>	
Subcontractor indicate name of contractor.	CONTRACT WORK: <u>Bid Package 1</u>
	JAILS CONTRACT NO: <u>139194</u>
	RFP No: <u>ASI#11</u>

I. SUMMARY OF DETAILED BREAKDOWN

Note: Detailed breakdown must be attached.

	Additions	Deletions	Net Total
A. MATERIAL		(\$3,590.00)	(\$3,590.00)
B. LABOR		(\$218.13)	(\$218.13)
C. OTHER			
D. NET TOTAL A+ B+C			(\$3,808.13)
E. OVERHEAD & PROFIT Line D X 15%* (min. \$100) additions only, deletions -0-			
F. TOTAL PROPOSAL FOR CONTRACTOR'S WORK		Lines D + E	(\$3,808.13)

II. CONTRACTORS MARKUP ON WORK OF SUBCONTRACTORS

Note: Detailed Breakdowns and summaries from each subcontractor must be attached.

SUBCONTRACTOR: Firm Name	CONTRACTOR WORK: Description	PROPOSAL **
_____	_____	_____
_____	_____	_____
_____	_____	_____
_____	_____	_____

G. SUBTOTAL of all work performed by contractor's subcontractors			_____
H. CONTRACTOR's MARK-UP on work of subcontractors (min. \$50)		Line G X 15% *	_____
I. TOTAL PROPOSAL FOR SUBCONTRACT WORK		Line G+H	_____

III. PROPOSAL

J. BONDS (_____ %) (if applicable)	Enter percentage as a number, for 10%, enter 10	_____
K. BUILDERS RISK INSURANCE (_____ %) (if applicable)		_____
L. TOTAL PROPOSAL OF THIS CONTRACTOR (for subject RFPCO)	Lines F+ I +J +K	(\$3,808.13)
M.		_____
N. PROPOSAL for subject RFPCO increase (decrease) in contract amount.	<input type="text"/>	(\$3,808.13)

O. Work to be accomplished in _____ Calendar Days from Approval of RFPCO.

CONTRACTOR

(Signature) _____ Title Project Manager Date 10/14/2020
 (Name Typed) Sheila J Zumbroegel

* As per Contract Documents, General Conditions
 ** Subcontractor's Proposal Amounts from Line N of Subcontractor's Form



ARCHITECT'S SUPPLEMENTAL INSTRUCTIONS

Project: Pottawattamie County, Iowa – Courthouse Renovation

HGM Project Number: 107419J

Approved By:

Sent to:

Owner
Architect
Contractor
Field
Other

X

Owner: Pottawattamie County Board of Supervisors

To Contractor: Ronco Construction Company Inc.

Supplemental Instruction No: **ASI #11 Control Room 31 Layout Changes**

Date: **September 17, 2020**

The Work shall be carried out in accordance with the following supplemental instructions issued in accordance with the Contract Documents without change in Contract Time. If there is a change in Contract Time or Cost, submit a Cost Summary on the Architect's Form, along with backup information with any change in contract time, before proceeding with the Work.

DESCRIPTION:

- 1. Revise the Control Room 031 layout per the attached plan on SD21.
- 2. Provide the Owner with a credit for Door 031B, (1) W7 window, and (1) bollard.

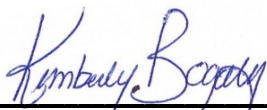
X 

Kimberly A. Bogatz, AIA LEED AP BD+C
HGM Associates Inc.

Attachments: SD21

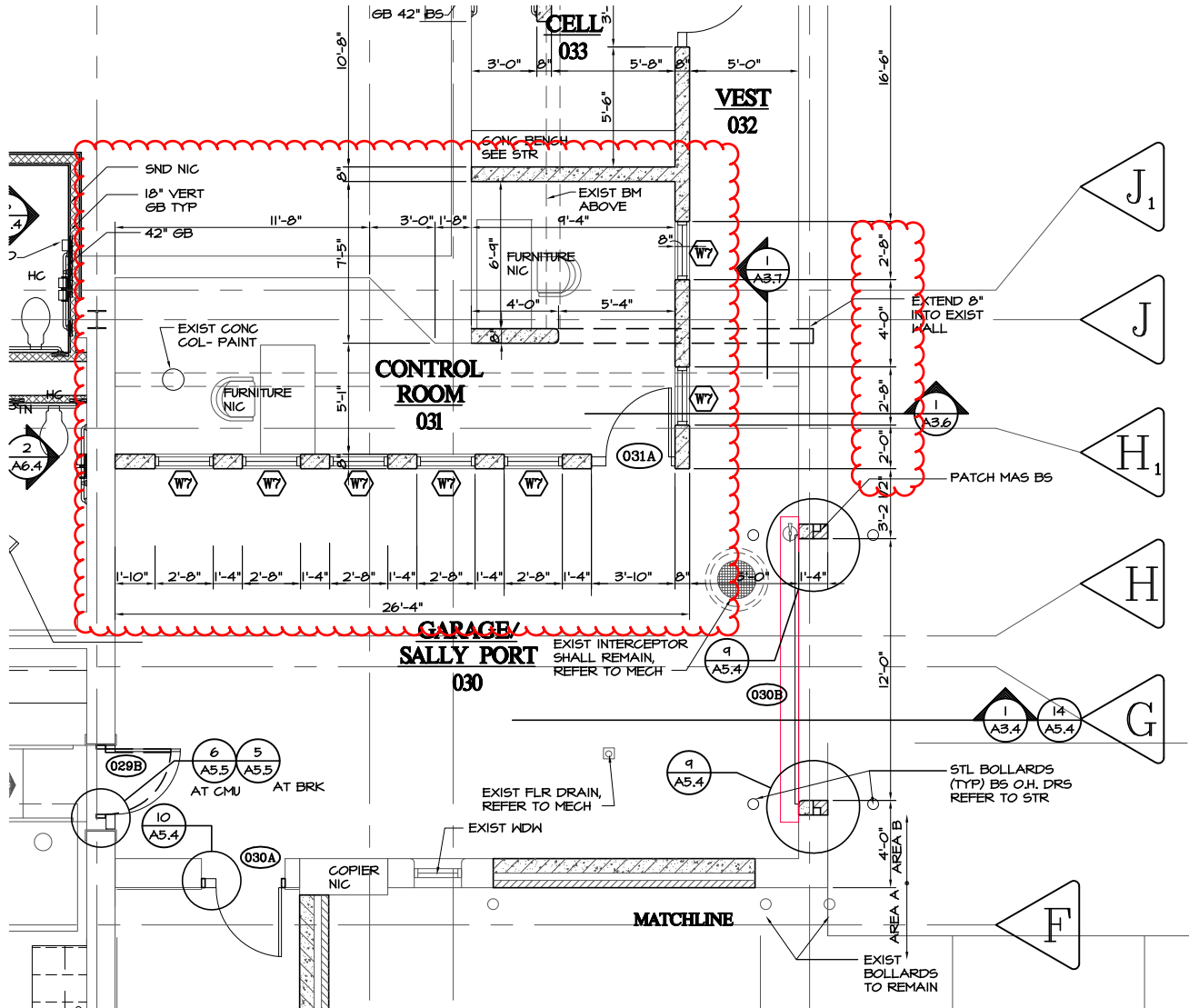

1 PARTIAL NORTH ELEVATION
 SCALE: 1/8"=1'-0"

**Jason Slack/Director,
Buildings & Grounds**

**Discussion and/or decision to approve:
CRC 047 – Door 034 Changes**



General Contractor's Cost Summary

PROJECT: Pottawattamie County, Iowa - Courthouse Renovation PROJECT NUMBER: 107419J
CONTRACTOR: Ronco Construction DATE: 3/1/2021

Contractor's Request for Change (CRC) # and Description: CRC 047 - Door 034 Changes
Reference: ASI # and Description

RFI # and Description RFI #50 Door and Frame Clarifications

Approved Declined

OWNER Date

Approved Declined

Handwritten signature: Kimberly A. Bogatz
Date: 3-3-21
Kimberly A. Bogatz, AIA

NOTE: This form, all Subcontractor/Material Supplier cost summary forms (if appropriate), itemized accountings and appropriate supporting data must be attached to any claim or contractor's request for change proposal for approval.

General Contractor Self Performed Work

- 1. Material supplied by General Contractor
2. General Contractor's Labor
3. Equipment
4. Subtotal (lines 1, 2 and 3)
5. Overhead and Profit (15% of line 4)
6. Total of General Contractor Self Performed Work

Subcontractor Installation/Work on Site

* (Attach Subcontractor/Supplier Cost Summary Sheet and Summaries/Breakdowns)

- 7. Subcontractor's cost summary (include but are not limited to the following:)
a. Mason
b. Drywaller
c. Roofer
d. Flooring
e. Painter
f. Plumber
g. HVAC
h. Electrician
i. Other: Security Equipment -2,565.00
j. Other
k. Other
l. Other
m. Other
8. Total Subcontractor's Cost (all lines under 7) -\$2,565.00
9. General Contractor's Overhead and Profit on Subcontractor's Work (5% of line 8)
10. Total of Subcontractor Installation/Work on Site (lines 8 and 9) -\$2,565.00

CONTRACTOR'S COST SUMMARY

CRC # _____

Project Name: Pottawattamie County, Iowa - Courthouse Renovation

Date: _____

Page 2 of 2

Material Supplier/Subcontractor Providing Materials Manufactured Off Site for General Contractor to Install On Site

*** (Attach Subcontractor/Supplier Cost Summary Sheet and Summaries/Breakdowns)**

11.	Materials Supplied by Sub or Material Supplier (include but are not limited to the following)	
	a. Structural Steel.....	_____
	b. Interior Architectural Woodwork.....	_____
	c. Doors.....	1,961.16
	d. Windows.....	_____
	e. Hardware.....	_____
	f. Other _____	_____
	g. Other _____	_____
	h. Other _____	_____
	i. Other _____	_____
12.	Subtotal of Materials Supplied.....	\$1,961.16
13.	General Contractor's Overhead and Profit (5% of line 12)	\$98.06
14.	Total of Materials Supplied by Subcontractor/Material Supplier	\$2,059.22
15.	Material Supplied by General Contractor.....	_____
16.	General Contractor's Labor.....	_____
17.	Equipment	_____
18.	Subtotal (lines 15, 16, and 17).....	_____
19.	Overhead and Profit (15% of line 18).....	_____
20.	Total of General Contractor (lines 18 and 19).....	_____
<hr/>		
21.	Subtotal (lines 6, 10, 14, and 20)	-\$505.78
22.	Bond at <u>-\$5.06</u> and Insurance at <u>-\$5.06</u>	-\$10.12
23.	Total Contractors Request for Change (CRC) (lines 21 and 22)	-\$515.90

Completing the information on this sheet will populate the other sheets with the basic information.

Project Number	139194
Project Name	Pottawattamie County Courthouse Council Bluffs, IA
Contract Number	139194
Contract Work (Trade)	Bid Package 1
RFP NO.	50
CONTRACTOR NAME	Jails Correctional Products
ADDRESS	350 South Ohio Street
CITY, STATE, ZIP	Minster, OH 45865
DATE:	10/14/2020

Jails Correctional Products

Contractor's/Subcontractor's
 Proposal Breakdown Summary
 Date: 10/14/2020

FROM: Contractor/Subcontractor Name, Address	Project No. <u>139194</u>
<u>Jails Correctional Products</u>	<u>Pottawattamie County Courthouse</u>
<u>350 South Ohio Street</u>	<u>Council Bluffs, IA</u>
<u>Minster, OH 45865</u>	
Subcontractor indicate name of contractor.	CONTRACT WORK: <u>Bid Package 1</u>
	JAILS CONTRACT NO: <u>139194</u>
	RFP No: <u>50</u>

I. SUMMARY OF DETAILED BREAKDOWN

Note: Detailed breakdown must be attached.

	Additions	Deletions	Net Total
A. MATERIAL		(\$2,565.00)	(\$2,565.00)
B. LABOR			
C. OTHER			
D. NET TOTAL A+ B+C			(\$2,565.00)
E. OVERHEAD & PROFIT	Line D X 15%* (min. \$100) additions only, deletions -0-		
F. TOTAL PROPOSAL FOR CONTRACTOR'S WORK	Lines D + E		(\$2,565.00)

II. CONTRACTORS MARKUP ON WORK OF SUBCONTRACTORS

Note: Detailed Breakdowns and summaries form each subcontractor must be attached.

SUBCONTRACTOR: Firm Name	CONTRACTOR WORK: Description	PROPOSAL **

G. SUBTOTAL of all work performed by contractor's subcontractors		
H. CONTRACTOR'S MARK-UP on work of subcontractors (min. \$50)	Line G X 15% *	
I. TOTAL PROPOSAL FOR SUBCONTRACT WORK	Line G+H	

III. PROPOSAL

J. BONDS (%) (if applicable)	Enter percentage as a number, for 10%, enter 10	
K. BUILDERS RISK INSURANCE (%) (if applicable)		
L. TOTAL PROPOSAL OF THIS CONTRACTOR (for subject RFPCO)	Lines F+ I +J +K	(\$2,565.00)
M.		

N. PROPOSAL for subject RFPCO increase (decrease) in contract amount. (\$2,565.00)

O. Work to be accomplished in _____ Calendar Days from Approval of RFPCO.

CONTRACTOR
 (Signature) _____ Title Project Manager Date 10/14/2020
 (Name Typed) Sheila J Zumbroegel

* As per Contract Documents, General Conditions
 ** Subcontractor's Proposal Amounts from Line N of Subcontractor's Form

CHANGE ORDER PROPOSAL SUMMARY COMPUTATIONS

CONTRACTOR	Jails Correctional Products	PROJECT NO.	139194
CONTRACT NO.	139194	PROJECT NAME	Pottawattamie County Courthouse
RFP NO.	50		Council Bluffs, IA
DATE	10/14/2020		

A. MATERIAL

1. Rough Material _____ + Freight/Cartage	=	
2. Purchased Equipment (Quotations must be attached)		
a. <u>Trussbilt HM C.O. #20229 Credit</u>		(\$1,165.00)
b. <u>Southern Folgers Hardware DH03</u>		(\$1,400.00)
c. _____		
d. _____		
Total Equipment Costs		(\$2,565.00)
	TOTAL MATERIAL COST	(\$2,565.00)

B. LABOR

1. Trade	Carpenter	Journeyman		x	\$46.41	=	
		Foreman		x		=	
		Gen Foreman		x		=	
2. Trade		Journeyman		x		=	
		Foreman		x		=	
		Gen Foreman		x		=	
3. Trade		Journeyman		x		=	
		Foreman		x		=	
		Gen Foreman		x		=	
							TOTAL LABOR COSTS

C. OTHER COSTS

1. Tool Allowance		7.		
2. Rental Equipment		8.		
3. Shop Drawings		9.		
4. _____		10.		
5. _____		11.		
6. _____		12.		
			TOTAL OTHER COSTS	



Walsh Door & Security
 2600 Delaware Ave
 Des Moines, IA 50317
 Tel: 515-262-9822 Fax: 515-262-8315

Sales Order

Sales Order # : **545150**
 Order Date : **Feb 23, 2021**

Customer:
 Ronco Construction Company, Inc.
 1717 N 74th St.
 Omaha, NE 68114

Ship To:
 1-20135 - Pottawattamie County
 Courthouse Renovation
 227 S 6th Street
 Council Bluffs, IA 51501

Account Code	: 2777	Date Requested	: Feb 24/2021
Terms	: Net15	Purchase Order #	: 1-20135
Customer Job #	: 1-20135	Quote #	:
Salesperson	: Benton Welling	Contact	: Benton Welling
Order Name	: 1-20135 - Pott Co. Opening 034 - RFI #50		

Material supplier only

Delivery Note: Daryl 402-510-7866

Qty Product Description

- 1 SU 16 CRS 534 SGL 2470 KD H400 LH (S; F-CL REIN; F-CUT/HEAD; F-DP SWITCH DIA; F-ELEC BOX(2); F-EOA; F-LSE; F-WELD 3-SIDE; QF-QS LABOR-1; QF-QS LABOR-1/2)
Openings: 034
- 8 Existing Opening Fastener (5" Dynabolt) (7000010)
Openings: 034(8)
- 1 HMD RI 18 GA. CRS 2470 F 1 3/4 RHR (45R; C1; LM2; MAG_34; STC)
Openings: 034
- 3 Hinges CB179 4 1/2 X 4 1/2 NRP US26D
Openings: 034(3)
- 1 Closer 4040 XP SCUSH TBSRT AL
Openings: 034
- 1 Lockset 63 8204 LNL (111111) LA KEYWAY RHR 26D
Openings: 034
- 0 Door Position Switch DPS-M-GY
- 0 Electric Strike Body 1006 630
- 0 Face Plate KM 630
- 1 Protection Plate KP50 8" x 26" CSK US32D
Openings: 034

Pre-Tax Total	:	1,961.16
078 IA POTTAWATTAMIE 7%	:	137.28
Order Total	:	2,098.44



Ronco Construction Company Inc.
1717 N 74th Street
Omaha, Nebraska 68114-1805
Phone: (402) 397-9109
Fax: (402) 397-8799

Project: 8204 - Pottawattamie Courthouse
227 S 6th St
Council Bluffs, Iowa 51503

DOOR AND FRAME CLARIFICATIONS

TO:	Sheryl Renfeld (HGM Associates) Ryan TerSteege (HGM Associates) Kimberly Bogatz (HGM Associates)	FROM:	Benton Welling (Walsh Door & Security)
DATE INITIATED:	09/09/2020	STATUS:	Open
LOCATION:		DUE DATE:	09/14/2020
PROJECT STAGE:	Course of Construction	COST CODE:	
SUB JOB:		SCHEDULE IMPACT:	
COST IMPACT:		SPEC SECTION:	08 11 13 - Hollow Metal Doors and Frames
DRAWING NUMBER:		REFERENCE:	
LINKED DRAWINGS:			
RECEIVED FROM:	Benton Welling (Walsh Door & Security)		
COPIES TO:	Nate Bledsoe (Ronco Construction Company), Kimberly Bogatz (HGM Associates), Darrell Darling (Ronco Construction Company), Jimmy Esola (Ronco Construction Company), Sheryl Renfeld (HGM Associates), Jason Slack (Pottawattamie County), Ryan TerSteege (HGM Associates)		

Question from Benton Welling (Walsh Door & Security) at 03:41 PM on 09/08/2020

Opening 223 – Has this opening been deleted? It stated deleted or moved on our shop drawings. Please advise.
 Opening 018 – Advise each door panel size at this pair. Plans show unequal pair.
 Opening 034 – Confirm door and frame are now standard commercial swinging, not detention.
 Opening 034 – Advise which architectural hardware set to use at this opening.

Awaiting an Official Response

All Replies:

Door 223 - The door has been moved per ASI #006. The note should have been updated on the shop drawing comments.

Door 018 - Door panel sizes as scheduled. The smaller door will be locked and the larger door will be open. Need to have the larger door for ADA.

Door 034 - Not a detention door - Use hardware set #2. (Same set as door 009)

KAB/RDT
 BY _____ DATE 9-14-20 COPIES TO _____

**Jason Slack/Director,
Buildings & Grounds**

**Discussion and/or decision to approve:
CRC 026R – 2 Hour Ceiling @
Hall 040**



General Contractor's Cost Summary

PROJECT: Pottawattamie County, Iowa - Courthouse Renovation PROJECT NUMBER: 107419J
 CONTRACTOR: Ronco Construction DATE: 3/1/2021

Contractor's Request for Change (CRC) # and Description: CRC 026R - 2 HR Ceiling @ Hall 040
 Reference: ASI # and Description
 RFI # and Description

<input type="checkbox"/> Approved	<input type="checkbox"/> Declined
<hr/>	
OWNER	Date
<input checked="" type="checkbox"/> Approved	<input type="checkbox"/> Declined
<hr/>	
	<u>3-3-21</u>
Kimberly A. Bogatz, AIA	Date

NOTE: This form, all Subcontractor/Material Supplier cost summary forms (if appropriate), itemized accountings and appropriate supporting data must be attached to any claim or contractor's request for change proposal for approval.

General Contractor Self Performed Work

1. Material supplied by General Contractor.....
2. General Contractor's Labor.....
3. Equipment
4. Subtotal (lines 1, 2 and 3).....
5. Overhead and Profit (15% of line 4).....
6. **Total of General Contractor Self Performed Work**.....

Subcontractor Installation/Work on Site

* (Attach Subcontractor/Supplier Cost Summary Sheet and Summaries/Breakdowns)

7. Subcontractor's cost summary (include but are not limited to the following:):
 - a. Mason
 - b. Drywaller 2,290.00
 - c. Roofer
 - d. Flooring
 - e. Painter -218.00
 - f. Plumber
 - g. HVAC
 - h. Electrician
 - i. Other
 - j. Other
 - k. Other
 - l. Other
 - m. Other
8. **Total Subcontractor's Cost (all lines under 7)**..... **\$2,072.00**
9. General Contractor's Overhead and Profit on Subcontractor's Work (5% of line 8) \$103.60
10. **Total of Subcontractor Installation/Work on Site (lines 8 and 9)**..... **\$2,175.60**

CONTRACTOR'S COST SUMMARY

CRC # _____

Project Name: Pottawattamie County, Iowa - Courthouse Renovation

Date: _____

Page 2 of 2

Material Supplier/Subcontractor Providing Materials Manufactured Off Site for General Contractor to Install On Site

*** (Attach Subcontractor/Supplier Cost Summary Sheet and Summaries/Breakdowns)**

- 11. Materials Supplied by Sub or Material Supplier (include but are not limited to the following)
 - a. Structural Steel.....
 - b. Interior Architectural Woodwork.....
 - c. Doors.....
 - d. Windows.....
 - e. Hardware.....
 - f. Other _____
 - g. Other _____
 - h. Other _____
 - i. Other _____
- 12. Subtotal of Materials Supplied.....
- 13. General Contractor's Overhead and Profit (5% of line 12)
- 14. **Total of Materials Supplied by Subcontractor/Material Supplier**
- 15. Material Supplied by General Contractor.....
- 16. General Contractor's Labor.....
- 17. Equipment
- 18. Subtotal (lines 15, 16, and 17).....
- 19. Overhead and Profit (15% of line 18).....
- 20. **Total of General Contractor (lines 18 and 19)**.....

21.	Subtotal (lines 6, 10, 14, and 20)	\$2,175.60
22.	Bond at <u> \$21.76 </u> and Insurance at <u> \$21.76 </u>	\$43.51
23.	Total Contractors Request for Change (CRC) (lines 21 and 22)	\$2,219.11

Johnson Drywall Company, Inc.

301 East First Street - Papillion, NE 68046

Ph (402) 592-0079 Fax (402) 592-3820

Change Proposal Request #

8

Project Name: Pott. Co. Courthouse Reno
Project Address: 227 S. 6th St - CB, IA
Date: 12/2/2020

Submitted To: Ronco Construction
Attn: Nate/Jim
Fax Number: _____

Description of Change: Labor & material to provide a 2HR rated ceiling in Hallway 040 @ 8'-0" AFF.

Material:

1) <u>SW Framing 2 1/2" x 20ga</u>	128	Units @	\$1.00	\$128.00
2) <u>SW Liner x 1"</u>	120	Units @	\$0.70	\$84.00
3) <u>GWB 5/8" FR</u>	336	Units @	\$0.35	\$117.60
4) <u>Finish</u>	100	Units @	\$0.20	\$20.00
5) _____	0	Units @	\$0.00	\$0.00
6) _____	0	Units @	\$0.00	\$0.00
7) _____	0	Units @	\$0.00	\$0.00

Material Subtotal \$349.60 \$349.60

Labor:

1) <u>Carpenter</u>	24	Hours @	\$32.00	\$768.00
2) <u>Finisher</u>	10	Hours @	\$32.00	\$320.00
3) <u>Laborer</u>	4	Hours @	\$32.00	\$128.00
4) _____	0	Hours @	\$0.00	\$0.00

Labor Subtotal \$1,216.00 \$1,216.00

Subcontractor:

1) _____	0	Lump Sum @	\$0.00	\$0.00
2) _____	0	Lump Sum @	\$0.00	\$0.00

Subcontractor Subtotal \$0.00 \$0.00

Equipment:

1) _____	0	Lump Sum @	\$0.00	\$0.00
2) _____	0	Lump Sum @	\$0.00	\$0.00

Equipment Subtotal \$0.00 \$0.00

Markups:

Sales Tax on Material	0.00%	\$0.00
Sales Tax on Equipment	7.00%	\$0.00
Burden on Labor	35.00%	\$425.60

		\$1,991.20	\$1,991.20
Overhead & Profit (Material)	15.00%		\$52.44
Overhead & Profit (Labor)	15.00%		\$246.24
Overhead & Profit (Subcontractor)	10.00%		\$0.00
Overhead & Profit (Equipment)	15.00%		\$0.00

Bond	0.00%		\$2,289.88
			\$0.00

\$2,290

Larsen Painting

15 S 14th Street
Council Bluffs, IA 51501 US
+1 4026591695
larsenmike60@gmail.com

Estimate

ADDRESS
Pottawattamie County Courthouse Renovation

ESTIMATE 1096
DATE 03/01/2021

SERVICE	DESCRIPTION	QTY	RATE	AMOUNT
	Deductions on project.			
Sales	Deduct cost for not painting ceilings in rooms 026, 027, and 057		1,887.00	1,887.00
Sales	Deduct cost for changes in Hallway 040.		218.00	218.00
TOTAL				\$2,105.00

Accepted By

Accepted Date

**Jason Slack/Director,
Buildings & Grounds**

**Discussion and/or decision to approve:
Change Order for 2 exterior
cameras at the Annex Building**

Empowering People Through Intelligent Buildings

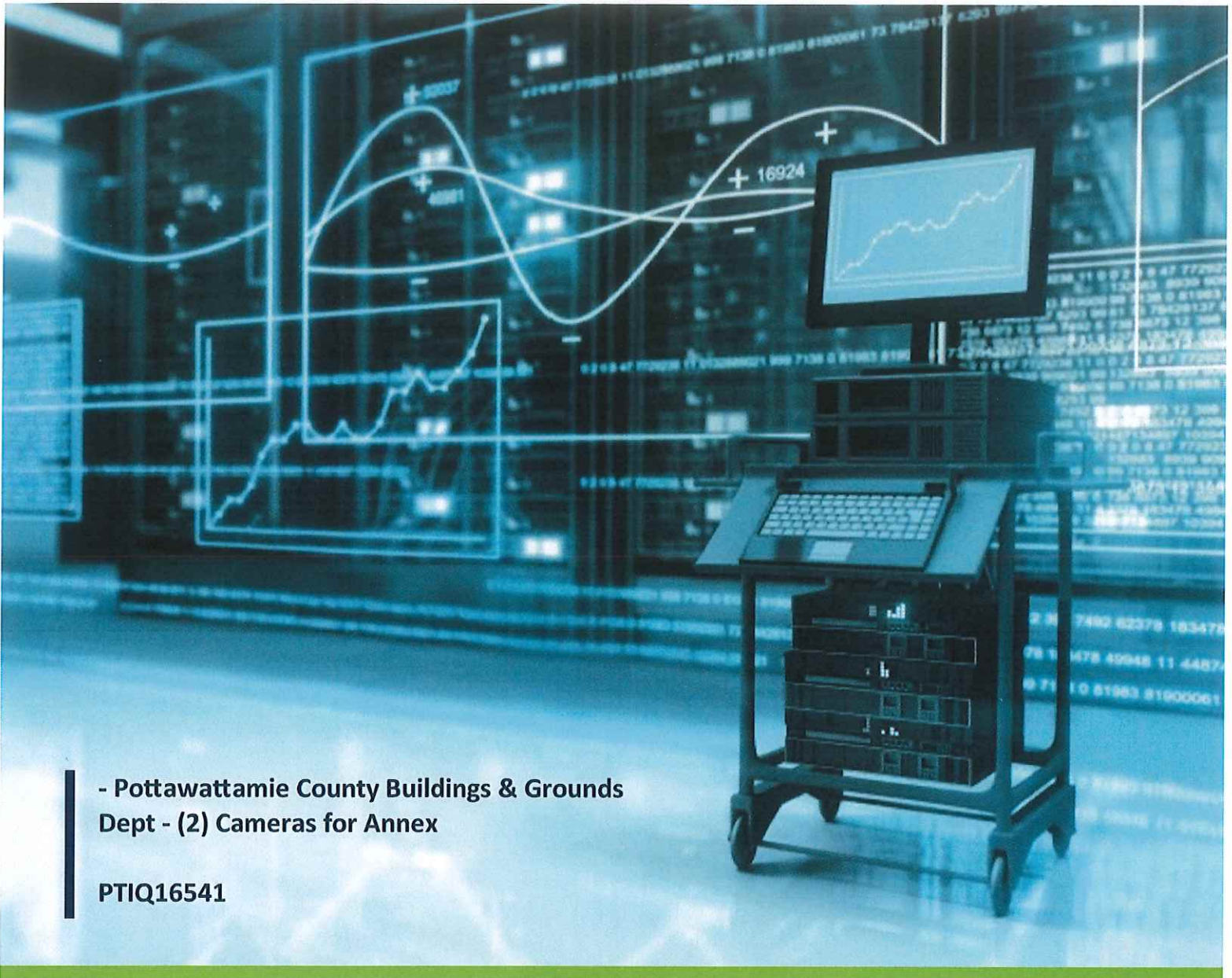

- Pottawattamie County Buildings & Grounds
Dept - (2) Cameras for Annex

PTIQ16541

Prepared for:

Pottawattamie County Buildings
& Grounds Dept
Jason Slack
jason.slack@pottcounty-ia.gov



PARALLEL TECHNOLOGIES



Detailed Scope of Work

Here is the quote you requested.

-Provide (2) Axis P3245-LVE camreas to replace (2) Honeywell cameras that are not supported by Genetec OmniCast.
Services are included to add IP addresses to each camera.

Standard Assumptions

Please contact me if I can be of further assistance.

-Product only with the exception of professional services to add IP addresses to each camera.

Client will install.

Licenses were accounted for in the base scope of work/bill of materials.



 **Bill of Materials**

Qty	Mfr Model #	Description	Unit Price	Extended Price
Cameras for Annex Building				
Product				
2	01593-001	Axis P3245-LVE Network Camera		
SubTotal				\$1,362.64
Services				
0.5	P100-PS	Programming	\$130.44	\$65.22
0.5	PM	Project Management	\$81.71	\$40.86
0.5	PC	Project Coordination	\$59.79	\$29.90
SubTotal				\$135.98
Products & Services Total:				\$1,498.62



Quote #PTIQ16541 - - Pottawattamie County Buildings & Grounds Dept - (2) Camera

Prepared by:

Parallel Technologies, Inc.

Brandon Rogotzke

952-278-0344

brogotzke@ptnet.com

Prepared for:

Pottawattamie County Buildings &

227 South 6th Street

Council Bluffs, IA 51501

Jason Slack

jason.slack@pottcounty-ia.gov

Quote Information:

Quote #: PTIQ16541

Delivery Date: 02/19/21

Expiration Date: 03/21/21

Quote Summary

Description	Amount
Products & Services	\$1,498.62
Sales Tax Rate	EXEMPT
Estimated Sales Tax	\$0.00
Quote Total:	\$1,498.62

PTI Terms and Conditions:

Section 1 - The Work

This proposal takes precedence over any and all prior proposals, correspondence, and oral agreements or representation relating to the work set forth in the attached scope of work. This proposal commences on the Start Date as specified in the attached scope of work, and represents the entire agreement between Parallel and the Customer. In the event any provision of this Agreement is held to be invalid or unenforceable, the remaining provisions of this Agreement shall remain in full force.

Section 2 - Pricing

Pricing and amounts proposed shall remain valid for 30 days unless otherwise specified. Price includes only the material listed based on Parallel's interpretation of plans and specifications unless otherwise noted. Shipping and sales taxes, and any other taxes assessed on Customer shall be added to the price upon invoice to customer, unless otherwise note in the proposal.

Section 3 - Invoice remittance and Payment

Customer agrees to standard payment terms of 100% of materials billed on acceptance, 50% of labor on install start and progress for remainder. If the project extends sixty (60) days or more, Parallel will invoice for products and material when ordered, and progress billing for services. Customer agrees to pay the amount due to Parallel as invoiced within 30 days of the date of being invoiced. If Customer is overdue in any payment to Parallel, Parallel shall be entitled to suspend the Work until paid and charge Customer an interest rate of 1 and ½% per month, and may avail itself of any other legal or equitable remedy. Customer shall reimburse Parallel costs incurred in collecting any amounts that become overdue, including attorney fees, court costs and any other reasonable expenditure.

Section 4 - Warranty

Parallel provides the following warranty to the Customer:

For a period of one year, commencing on the earlier of substantial completion of work, or first beneficial use, ("Warranty Period"):

- A. The Work performed under this agreement will be of good quality,
- B. That all equipment will be new unless otherwise required or permitted by this agreement,
- C. That the Work will be free from defects not inherent in the quality required or permitted; and
- D. That the Work will conform to the requirements of this agreement.



The Customer's sole remedy for any breach of this warranty is that Parallel shall remove, replace and/or repair at its own expense any defective or improper Work, discovered within the Warranty Period, provided Parallel is notified in writing of any defect within the Warranty Period. Any equipment or products installed by Parallel in the course of performing the Work hereunder shall only carry such warranty as is provided by the manufacturer thereof, which Parallel hereby assigns to Customer without recourse to Parallel. Upon request of Customer, Parallel will use all reasonable efforts to assist Customer in insufficient maintenance, improper operation, or normal wear and tear under normal usage. NO FURTHER WARRANTIES OR GUARANTEES, EXPRESS OR IMPLIED, ARE MADE WITH RESPECT TO ANY GOODS OR SERVICES PROVIDED UNDER THIS AGREEMENT, AND ANY IMPLIED WARRANTIES OF MERCHANTABILITY OR FITNESS FOR A PARTICULAR PURPOSE ARE EXPRESSLY DISCLAIMED.

Section 5 - Changes

Without invalidating this Agreement, Customer or Parallel may request changes in the Work. Any changes to the Work and any adjustment to the Agreement Price or the time for completion of the Work shall be in writing signed by both Customer and Parallel. If Customer orders any additional work or causes any material interference with Parallel's performance of the Work, Parallel shall be entitled to an equitable adjustment in the time for performance and in the Agreement Price.

Section 6 - Force Majeure

Neither Customer or Parallel shall be responsible or liable for, shall incur expense for, or be deemed to be in breach of this Agreement because of any delay in the performance of their respective obligation pursuant to this Agreement due solely to circumstances beyond their reasonable control ("Force Majeure") and without the fault or negligence of the party experiencing such delay, provided that the party experience the delay shall promptly give written notification to the other party within 5 days after such party has learned of the Force Majeure.

Section 7 - Indemnification

Parallel shall indemnify and hold customer harmless from and against claims, damages, losses and expenses, (including, but not limited to, reasonable attorney's fees) attributable to bodily injury, sickness, disease or death, or to destruction of tangible property, but only to the extent caused by: a) the negligent or willful acts or omissions of Parallel or Parallel's employees or subcontractors while on the Customer's site, or b) the malfunction of the equipment supplied by Parallel, or c) Parallel's breach of this agreement. In no event shall either Parallel or Customer be liable to the other party hereto for special, indirect, incidental, or consequential damages, including commercial loss, loss of use or lost profits, even if that party has been advised of the possibility of such damages. In no event will Parallel Technologies be liable to customer for any amounts in excess of the amounts paid by Customer to Parallel.

Section 8 - Disputes

In the event of any dispute between Parallel and Customer, Parallel and Customer shall first attempt to resolve the dispute in the field, but if that is not successful, then in a meeting between authorized officers of each company. If settlement attempts are not successful, then the dispute shall be subject to and decided by mediation or arbitration.

Parallel Technologies, Inc.

Pottawattamie County Buildings & Grounds Dept

Signature: _____

Signature: _____

Name: Brandon Rogotzke

Name: Jason Slack

Date: 2/19/2021

Date: _____

John Rasmussen/County Engineer

**Discussion and/or decision to approve
Right of Way purchase contract with
Keith A and Mark W Bentley for project
STBG-SWAP-CO78(204)-FG-78**

CONTRACT

THIS AGREEMENT Made and entered into this 4th of MARCH, A.D. 2021

By and between Keith A. Bentley and Mark W. Bentley, as Tenants in Common, 1/2 interest each.

Address 20343 340th Street, Oakland, IA 51560
of the County of Pottawattamie, party of the first part, and Board of Supervisors, acting for Pottawattamie County Iowa, party of the second part.

WITNESSETH:

In consideration of \$758.34 receipt of which is hereby acknowledged, the party of the first part hereby agrees to furnish to the second party a warranty deed, or an easement for use as a public highway, to the real estate situated in the County of Pottawattamie, State of Iowa, to-wit:

In Section 11 Township 75N Range 41W

As shown on plans for Project No. STBG-SWAP-C078(204)—FG-78 Additional Rights of Way as follows:

See attached legal description.

It is hereby agreed that possession of the premises is the essence of this contract and that party of the second part may take immediate possession of the premises upon the signing of this contract for the purposes above set forth, and first party agrees to convey to second party for the consideration hereinafter named, on or before the 4th day of MARCH, 2021.

Party of the second part agrees to purchase the above described real estate or take easement thereto for road purposes and to pay therefore upon delivery of warranty deed, or easement, showing merchantable title.

Approx. 0.030 acres at \$9,211.20 per acre (Perm. Easement)	\$ 276.34
Right-of-way Fence - Material's and Labor	\$ 332.00
Abstract Allowance	<u>\$ 150.00</u>
TOTAL =	\$ 758.34

Should the acreage taken for highway be more or less than shown above, same is to be paid for at the agreed unit price. Any and all verbal agreements are merged in this written contract. Should the highway as finally located require none of the real estate described, this contract becomes null and void.

Party of the first part consents to the establishment of the proposed road and relinquishes all claims for damages.

(Signed) Keith Bentley
Party of the First Part

Mark Bentley

(Signed) POTTAWATTAMIE COUNTY

By _____, Chairman
Party of the Second Part

DOCUMENT PREPARED BY POTTAWATTAMIE COUNTY ENGINEER'S OFFICE
RIGHT OF WAY
ACQUISITION PLAT

ACQUIRED FROM KEITH A. BENTLEY AND MARK W. BENTLEY, AS TENANTS IN COMMON,
1/2 INTEREST IN EACH.

I hereby certify that this surveying document was prepared and the related survey work was performed by me or under my direct personal supervision and that I am a duly licensed Land Surveyor under the laws of the State of Iowa.

James E. Terry 9 Feb. 2021
Date
James E. Terry, L.S.
License number 11702
My license renewal date is December 31, 2021
Pages or sheets covered by this seal.
Sheet 1 of 2 and Sheet 2 of 2.

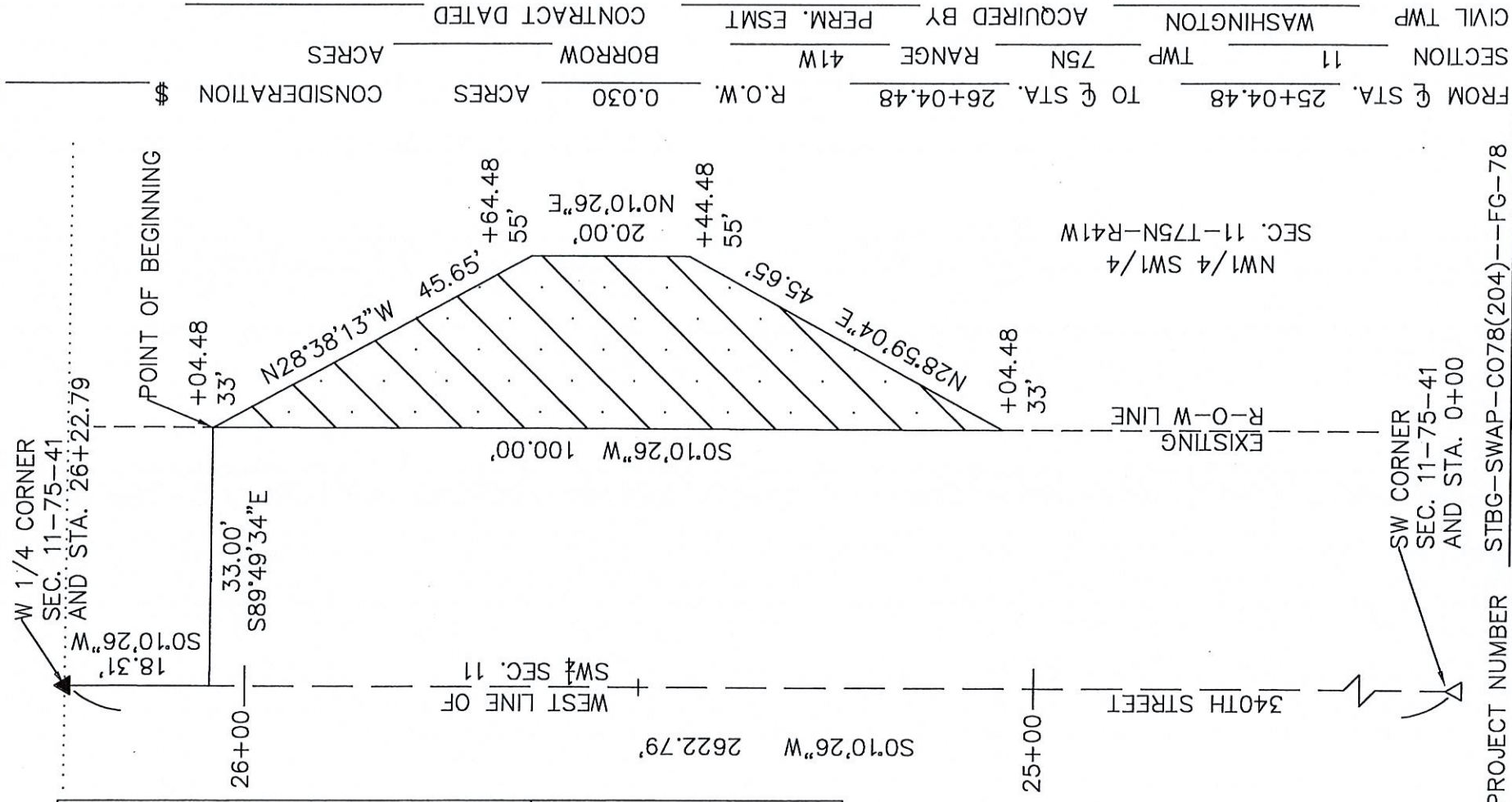
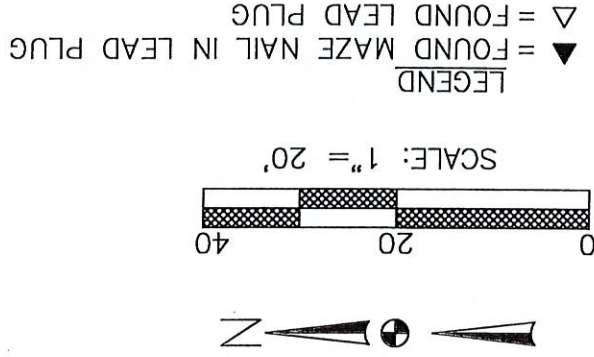
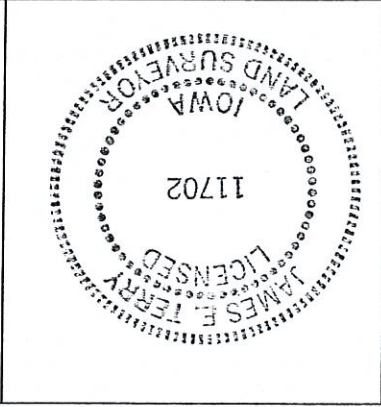

FROM	TO	R.O.W.	ACRES	CONSIDERATION	\$
STATION 25+04.48	STATION 26+04.48	0.030	0.030		
SECTION 11	TWP 75N	RANGE 41W	BORROW		
CIVIL TWP	WASHINGTON	ACQUIRED BY	PERM. ESMT	CONTRACT DATED	

Parcel No. 1

Legal Description:

A parcel of land located in part of the NW1/4 SW1/4 of Section 11, Township 75 North, Range 41 West of the 5th Principal Meridian, Pottawattamie County, Iowa, more particularly described as follows:

Commencing at the West ¼ corner of said Section 11, thence S00°10'26"W along the West line of said NW1/4 SW1/4 a distance of 18.31 feet to a point being station 26+04.48 on the West line of said NW1/4 SW1/4; thence S89°49'34"E a distance of 33.00 feet to a point on the East right-of-way line of 340th Street, being station 26+04.48, 33.00 feet right of the West line of said NW1/4 SW1/4 and the Point of Beginning; thence S00°10'26"W along said East right-of-way line a distance of 100.00 feet to a point being station 25+04.48, 33.00' right of the West line of said NW1/4 SW1/4; thence N28° 59' 04"E a distance of 45.65 feet to a point being station 25+44.48, 55.00 feet right of the West line of said NW1/4 SW1/4; thence N00° 10' 26"E a distance of 20.00 feet to a point being station 25+64.48, 55.00 feet right of the West line of said NW1/4 SW1/4; thence N28° 38' 13"W a distance of 45.65 feet to the Point of Beginning. Said parcel contains 0.030 acres, more or less.

Note: The West line of the NW1/4 SW1/4 of said Section 11 is assumed to bear S00° 10' 26"W for this description.

**Matt Wyant/Planning Director, Pam
Kalstrup/Acting Director, Mark Hughes,
Jim Hughes**

**Discussion and/or decision on
Rural Development**

Becky Lenihan/Assistant Finance Officer

**Discussion and/or decision on
Funding Request from SWIPCO
for \$11,716.90**



A Bright Look Ahead™

Forwarded to BB
1/13/21

0003-01-9030-000-48003-000

January 11, 2021

Pottawattamie County Supervisors
227 South 6th Street
Council Bluffs, IA 51501

Dear Supervisors:

Southwest Iowa Planning Council continues to be an effective mechanism for local capacity development and regional cooperation. SWIPCO's strength lies in the support and utilization of our member governments, and we are proud to be your partner.

During your FY 22 budget process, we request that you allocate \$11,716.90 (18,026 rural population x \$.65) as dues to the Southwest Iowa Planning Council. This is only a request for the allocation; we will present an invoice in June 2021. This is level with the per capita request that has been in place for over 10 years. Last year, the board did vote to approve a gradual increase in dues, but recently voted to rescind that increase because of the impacts of Covid-19. SWIPCO receives significant grant support but does need to collect dues as local funds to match those grants.

We look forward to assisting with southwest Iowa's growth and development and look forward to working with you in the coming year. Please contact me at 866-279-4720 if you have any questions.

Sincerely,

John McCurdy
Executive Director

Becky Lenihan/Assistant Finance Officer

**Discussion and/or decision on
Funding Request from SWITA
for \$6,000**



0003-01-3400-000-35700-000

A Bright Look Ahead™

January 11, 2021

Pottawattamie County Supervisors
227 South 6th Street
Council Bluffs, IA 51501

Dear Supervisors:

As the Board of Supervisors begins their budget process for FY 2022, Southwest Iowa Transit Agency (SWITA) requests that the Board allocate \$6,000.00 for support of the SWITA services in Pottawattamie County. This is the same amount that we have requested for many years. During Covid-19 SWITA has never stopped providing service. Although we have received CARES Act funding and that has helped us operate during these challenging times. Local funding support is still vital and assists with matching grants.

This is only a request for the allocation; we will send an invoice in June 2021. Please contact me at 866-279-4720 if you have any questions or would like to discuss this request in person.

Sincerely,

John McCurdy
Executive Director

Becky Lenihan/Assistant Finance Officer

**Discussion and/or decision on
Funding Request from Hungry
Canyons Alliance for \$4,500**

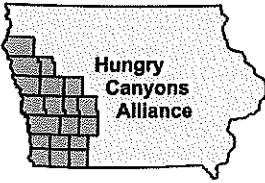

Hungry Canyons Alliance

P.O. Box 189
712 S. Hwy. 6 & 59
Oakland, Iowa 51560
Phone (712) 482-3029
Fax (712) 482-5590

January 4, 2021

Pottawattamie County Board of Supervisors
Pottawattamie County Courthouse
Council Bluffs, Iowa 51501

Dear Supervisors:

Thank you for your continued support and participation in the Hungry Canyons Alliance. As of December 2020, 414 Hungry Canyons Alliance streambed structures have been approved for cost share throughout the Deep Loess Region of western Iowa. Pottawattamie County has received approval for or completed 25 Hungry Canyons Alliance streambed stabilization structures with awards and payments totaling \$1,284,044. These structures protect an estimated \$9,317,884 in property value (bridges, farmland, utility lines, etc.). Pottawattamie County has also received \$167,690 in match from the HCA for 10 NRCS-EWP structures; another 16 NRCS-EWP projects are still in progress and will receive 10% match from the HCA. Sixteen private landowner projects in Pottawattamie County have also received a total of \$100,211 in cost share through the Hungry Canyons Small Structures Program.

To date, the Hungry Canyons Alliance has received \$11.94 million from the federal government and \$14.1 million from the State of Iowa. Member counties of Hungry Canyons Alliance have also supported the project, contributing membership fees of \$1,390,750. This strong support allows us to successfully address the problems associated with stream channel erosion in western Iowa. On average, for every \$1 invested in Hungry Canyons Alliance streambed stabilization structures, more than \$4.20 in property value and 0.88 tons of soil are protected from erosion.

To receive funds from Hungry Canyons Alliance, member counties are requested to pay an annual membership fee of \$4,500. Payment of this fee will give you membership in the Hungry Canyons Alliance from July 1, 2021 to June 30, 2022. An invoice is enclosed.

Unless notified, we will assume that Lynn Grobe will continue to serve on the Hungry Canyons Alliance Board of Directors.

Should you have any questions or require additional information please contact John Thomas, Project Director, at the telephone number above. Thank you again for your continued support and participation.

Sincerely,

John Thomas, Project Director
Hungry Canyons Alliance

Enc.

Cc: Pottawattamie County Engineer



Hungry Canyons Alliance

P.O. Box 189
712 S. Hwy. 6 & 59
Oakland, Iowa 51560
Phone (712) 482-3029
Fax (712) 482-5590

January 4, 2021

Invoice # HC-Pottawattamie

Pottawattamie County Board of Supervisors

Item #

1	Hungry Canyons Alliance Membership July 1, 2021 to June 30, 2022	\$4,500
---	---	---------

Total	\$4,500
-------	---------

Becky Lenihan/Assistant Finance Officer

**Discussion and/or decision on
Setting date & time for FY 22
Budget meeting**

Other Business

Discussion and/or decision:

**Designating April 2021 as Child
Abuse Prevention Month**

February 18, 2021

Dear Chairman Belt,

I am writing on behalf of Prevent Child Abuse Pottawattamie County to respectfully request your proclamation of April 2021 as "Child Abuse Prevention Month" in Pottawattamie County.

Child Abuse Prevention Month recognizes the importance of families and communities working together to prevent child abuse and neglect and promotes the social and emotional well-being of children and families. April is a time to help people understand that safe, stable and nurturing relationships and environments are necessary to ensure that children grow up happy and healthy. Women and children are at high risk during this time of isolation. We all play a role in supporting the well-being of others during this time.

Prevent Child Abuse Pottawattamie County (a committee of Promise Partners- Pottawattamie County's Alliance for Child and Family Well-Being) is participating in this year's Child Abuse Prevention Month and aiming to provide education and awareness to effectively address the needs of children and families.

I am attaching sample proclamation language that you might find helpful. For more information about child abuse prevention visit preventchildabuse.org.

I believe our county's active participation will have a positive effect on our community as this unifying celebration recognizes supporting children and families.

Thank you for your time and consideration.

Sincerely,

Lucy Hough

Promise Partners

Prevent Child Abuse Committee

**POTTAWATTAMIE COUNTY BOARD OF SUPERVISORS
PROCLAMATION**

CHILD ABUSE PREVENTION MONTH – APRIL 2021

WHEREAS, nationally, it is estimated that more than 1,540 children die each year from child abuse and neglect; and

WHEREAS, both locally and nationally, child abuse is considered to be one of the most serious public health problems with scientific studies documenting the link between the abuse and neglect of children and a wide range of medical, emotional, psychological and behavioral disorders; and

WHEREAS, promoting family functioning and resiliency, social support systems, concrete supports, nurturing and attachment, and knowledge of parenting and child development are all known protective factors which prevent child maltreatment and help strengthen families; and

WHEREAS, child abuse prevention is an acknowledged community responsibility. On behalf of Iowa’s children, this month and every month, we join Promise Partners to commit to prevent child abuse and neglect and to ensure a great childhood for every child.

THEREFORE, We, the Pottawattamie County Board of Supervisors, Do hereby proclaim April 2021 as

CHILD ABUSE PREVENTION MONTH

“In Pottawattamie County, Iowa and encourage all citizens, community agencies, religious organizations, medical facilities, and businesses to partner in efforts to prevent child abuse and neglect, thereby strengthening the communities in which we live.”

IN WITNESS WHEREOF, I have caused my signature and Seal of Pottawattamie County, Iowa to be affixed this 9th day of March, 2021.

ROLL CALL VOTE

	AYE	NAY	ABSTAIN	ABSENT
_____ Scott Belt, Chairman	<input type="radio"/>	<input type="radio"/>	<input type="radio"/>	<input type="radio"/>
_____ Tim Wichman	<input type="radio"/>	<input type="radio"/>	<input type="radio"/>	<input type="radio"/>
_____ Lynn Grobe	<input type="radio"/>	<input type="radio"/>	<input type="radio"/>	<input type="radio"/>
_____ Justin Schultz	<input type="radio"/>	<input type="radio"/>	<input type="radio"/>	<input type="radio"/>
_____ Brian Shea	<input type="radio"/>	<input type="radio"/>	<input type="radio"/>	<input type="radio"/>

Attest: _____
Melvyn Houser, County Auditor
Pottawattamie County, Iowa

Discussion and/or decision:

**Educational Reimbursement
Request from Megan Leggett**

ORIGINAL

POTTAWATTAMIE COUNTY
EDUCATIONAL REIMBURSEMENT REQUEST FORM

Employees who comply with the conditions set forth in the Educational Assistance Program policy as set forth in the Pottawattamie County Employee Handbook will be eligible to be reimbursed up to a maximum of fifty percent (50%) of the tuition cost per approved course. The maximum amount of reimbursement is \$1,100 per fiscal year. Courses must be job related and must have been approved by the Elected Official or Department Head prior to enrollment in the class.

This form must be completed and submitted to the Department Head for approval no less than thirty (30) days prior to the start of the course. Upon completion of the course, the employee must submit a copy of the grade(s) and the official record of tuition costs to the Board of Supervisors in order to receive reimbursement.

Name: Meagan Laygett Date Request Submitted 8-26-2020

Department: Jail Job Classification: Detention Supervisor

Educational Institution: Columbia Southern University Course Title: App. Appreciation 1 / Management and Supervision in Criminal Justice

Course Description: See attached

Course Start Date: 8-28-2020 Course Completion Date: 11-6-2020

Full Cost of Course Tuition: \$1,410.00 50% Reimbursement Request: \$705.00

[Signature]
Employee Signature

8-30-2020
Date

[Signature]
Approving Department Head

9-17-2020
Date

[Signature]
Board of Supervisors

9/22/20
Date

Employees will not be reimbursed for tuition associated with the course if they voluntarily leave the County or are terminated for reasons other than layoff or job elimination while they are enrolled in the class. Employees must agree in writing to repay the County in full if they leave the County voluntarily within one (1) year of completing the course. Employee Initials ml

BCJ 4301: Management and Supervision in Criminal Justice

Description

Presents an overview of supervisor and middle management roles in criminal justice agencies with an emphasis on the importance of inter-personal skills and co-worker relations as well as the positive and negative aspects of various leadership styles.

ART 1301: Art Appreciation I

Description

Explores two-dimensional art, including drawing, painting, photography, printmaking, collage, graphic design, animation and digital art as well as artists who make these works. While uncovering the global impact of two-dimensional art, students learn how to analyze and discuss two-dimensional artwork with others.

Received/Filed

Fee Book (02/01/2021 - 02/28/2021)

Criteria: {FMXFUS01_RPT_POTT.TndrDate} >= #02/01/2021# AND {FMXFUS01_RPT_POTT.TndrDate} <= #02/28/2021#

	Count	Total Fund Amount
Recording Fees		
RMA	1369	
E-Commerce	1369	\$1,379.00
Audit	289	\$1,379.00
Recording	1369	\$1,685.00
County Transfer Tax	155	\$33,045.00
State Transfer Tax	155	\$7,522.37
Photo Copies	23	\$36,086.43
Total For Recording Fees	4729	\$81,291.80
Other Fees		
COUNTY PASSPORT APPLICATION FUND	43	\$4,419.45
Total For Other Fees	43	\$4,419.45
Boats		
Boat Writing	11	
Boat State	10	\$28.75
Boat Title County	7	\$315.00
Boat Title State	7	\$40.00
Boat Liens State	1	\$52.00
Use Tax	11	\$6.50
Boat Lien County	1	\$5,088.84
Road Pass	6	\$5.00
DNR Postage	6	\$300.00
Total For Boats	60	\$5,846.09
ELSI		
ELSI County	33	
ELSI State	17	\$325.00
Total For ELSI	50	\$1,663.50
Vitals		
Cert Copy County	52	
Cert Copy State	52	\$2,580.00
Marriage County	30	\$7,095.00
Marriage State	30	\$120.00
Three Day Waiver	1	\$930.00
Total For Vitals	165	\$5.00
Collected Total:		\$10,730.00
Charged Total:		\$104,275.84
Grand Total:		\$49.00
		\$104,324.84

Recorder

39300	Feb-21	5195	\$51,304.57
Amount	Account #	Account Name	
\$2,700.00	0001-1-07-8110-413000-000	Vital Records	
\$1,379.00	0024-1-07-8110-400001-000	RMA	
\$325.00	0001-1-07-8110-409000-000	ELSI	
\$7,522.37	0001-1-07-8110-40400-000	Transfer Tax	
\$33,240.00	0001-1-07-8110-400000-000	Office Fees	
\$1,685.00	0001-1-07-8110-410000-000	Auditor Fees	
\$28.75	0001-1-07-8110-402000-000	Boat Writing Fee	
\$5.00	0001-1-07-8110-402000-000	Boat Liens	
\$4,419.45	0001-1-07-8110-414000-000	Passports	
\$51,304.57	Total	Checks prepared by: M.H.	Signed by: M.A.B.

Lynn Herrington, Deputy

Public Notice

Iowa Department of Natural Resources

Notice is hereby given that the Iowa Department of Natural Resources (IDNR) has under review a PSD construction permit application submitted by Bunge North America, 19560 Bunge Avenue, Council Bluffs, Iowa. The application is to replace modify the dehulling and increase the throughput of the facility.

Based upon the information provided by the applicant, IDNR has determined that according to PSD regulations the facility is a "major stationary source". This project is a modification of an existing PSD permit. This project has increases emissions of VOC above the PSD significance level and is subject to PSD for VOC. The increase in emissions of all other pollutants are below the PSD significance level, therefore no increment modeling was performed. A MERP analysis for VOC was performed. The permit application has met the requirements of 40 CFR 52.21 as adopted by the IDNR by reference in 567 Iowa Administrative Code 22.4 (455B).

A complete record of the permit review is available for public inspection at the Iowa Department of Natural Resources, Air Quality Bureau, 502 E. 9th Street, Des Moines, Iowa 50319 and at the Council Bluffs Public Library. All comments regarding this permit must be received on or before April 5, 2021. A public hearing to receive comments will be held if requested prior to March 18, 2021. Written and oral comments may also be directed to Gary Smith, Environmental Engineer, Air Quality Bureau, Iowa Department of Natural Resources, 502 E. 9th Street, Des Moines, Iowa 50319, 1-515-725-9563.

Upon the issuance of the permits, all comments and the final permits will be available to the public at the IDNR at the above Des Moines address and the Council Bluffs Public Library.

Closed Session