

Consent Agenda

March 28, 2023

MET IN REGULAR SESSION

The Board of Supervisors met in regular session at 10:05 A.M. All members present. Chairman Shea presiding.

PLEDGE OF ALLEGIANCE

1. CONSENT AGENDA

After discussion was held by the Board, a motion was made by Miller, and second by Jorgensen, to approve:

- A. March 21, 2023, Minutes as read.

UNANIMOUS VOTE. Motion Carried.

2. SCHEDULED SESSIONS

Brenda Mainwaring/President & CEO, Iowa West Foundation appeared before the Board to provide an update and discuss the 2023 Award Cycle 1.
Discussion only. No action taken.

Motion by Belt, second by Jorgensen, to support the Treynor Optimist and to have Board Chairman sign letter of support to be used for Treynor Optimist Club Impact grant request for the Can Kennel.

UNANIMOUS VOTE. Motion Carried.

Motion by Belt, second by Miller, to approve and authorize Board to sign corrected **Resolution No. 15-2023**, because of a clerical error and replacement of erroneous version with corrected version.

RESOLUTION NO. 15 -2023

WHEREAS, there were necessary expenses incurred in several county departments, causing the budget of that department to exceed 100% of costs; and

WHEREAS, the Public Health, Roads, Board Supervisors, Conservation and Non-Departmental have exceeded their Budget due to said necessary expenditures; and

WHEREAS, the Amendment to the Fiscal Year 2022/23 Budget for the Public Health, Roads, Board Supervisors, Conservation, and Non-Departmental shall be substantially as follows:

DEPT #	Revenue Amount	Expense Amount
Board of Supervisors - 01		\$ 210,000
Total		\$ 210,000
Roads - 20		\$ 675,000
Total		\$ 675,000
Conservation - 22	\$ 152,300	\$ 82,300
Total	\$ 152,300	\$ 82,300
Public Health - 23	\$ 368,387	\$ 246,976
Total	\$ 368,387	\$ 246,976
Non-Departmental - 99		\$ 440,866
Total	\$ -	\$ 440,866
	\$ 520,687	\$ 1,655,142

WHEREAS, the Board of Supervisors desires to allow those expenditures, and no tax increase will occur due to these expenditures; and

WHEREAS, the public had due notice of the Budget Amendment Hearing held on February 21,2023, and at the hearing, due time was allowed for objections to any and all portions of the amended budget.

NOW, THEREFORE BE IT RESOLVED, that the Board of Supervisors of Pottawattamie County, hereby amends the Fiscal Year 2022/23 budget.

Dated this 28th day of March, 2023.

ROLL CALL VOTE

	AYE	NAY	ABSTAIN	ABSENT
_____ Brian Shea, Chairman	<input type="radio"/>	<input type="radio"/>	<input type="radio"/>	<input type="radio"/>
_____ Scott Belt	<input type="radio"/>	<input type="radio"/>	<input type="radio"/>	<input type="radio"/>
_____ Tim Wichman	<input type="radio"/>	<input type="radio"/>	<input type="radio"/>	<input type="radio"/>
_____ Susan Miller	<input type="radio"/>	<input type="radio"/>	<input type="radio"/>	<input type="radio"/>
_____ Jeff Jorgensen	<input type="radio"/>	<input type="radio"/>	<input type="radio"/>	<input type="radio"/>

ATTEST: _____
Melvyn J. Houser, County Auditor

Roll Call Vote: AYES: Shea, Belt, Wichman, Miller, Jorgensen. Motion Carried.

Motion by Wichman, second by Belt, to approve and authorize Board to sign ARPA forgivable loan agreements with the small towns.

UNANIMOUS VOTE. Motion Carried.

3. OTHER BUSINESS

Motion by Belt, second by Miller, to approve and authorize Board to sign Resolution No. 13-2023, a Resolution to appointing Debra Redmon to the Southern Iowa Regional Housing Authority (SIRHA) Board of Commissioners with a three-year term ending on April 9, 2026.

RESOLUTION NO. 13-2023

BE IT RESOLVED BY THE BOARD OF SUPERVISORS OF THE COUNTY OF Pottawattamie, Iowa.

That the Board of Supervisors of the County of Pottawattamie, Iowa hereby make the following resolution.

WHEREAS, a resolution has been passed and adopted entitled "Resolution Approving and Authorizing the Execution of a Certain Joint Exercise of Powers Agreement for the Purpose of Creating a Multi-County Housing Authority."

NOW, THEREFORE, Pursuant to the provision of Chapter 28, Code of Iowa, and by virtue of our office as Supervisors, we hereby appoint Debra Redmon.

For three years, as the one (1) person to serve as Commissioner of the Southern Iowa Regional Hosing /authority, representing the County of Pottawattamie, Iowa, and to serve for the number of years appearing after his/her name, repetitively, from the ninth day of April 2023.

IN WITNESS WHEROF, I have hereunto signed my name as Chairman of the Board of Supervisors of the County of Pottawattamie, Iowa and caused the official corporate seal of said County of Pottawattamie, Iowa to be attached hereto this 28th day of March 2023.

Dated this 28th day of March 2023.

ROLL CALL VOTE

	AYE	NAY	ABSTAIN	ABSENT
_____ Brian Shea, Chairman	<input type="radio"/>	<input type="radio"/>	<input type="radio"/>	<input type="radio"/>
_____ Scott Belt	<input type="radio"/>	<input type="radio"/>	<input type="radio"/>	<input type="radio"/>
_____ Tim Wichman	<input type="radio"/>	<input type="radio"/>	<input type="radio"/>	<input type="radio"/>
_____ Susan Miller	<input type="radio"/>	<input type="radio"/>	<input type="radio"/>	<input type="radio"/>
_____ Jeff Jorgensen	<input type="radio"/>	<input type="radio"/>	<input type="radio"/>	<input type="radio"/>

ATTEST: _____
Melvyn Houser, County Auditor

Roll Call Vote: AYES: Shea, Belt, Wichman, Miller, Jorgensen. Motion Carried.

Lea Voss, Mark Shoemaker, Matt Wilber, and Jamie Petersen appeared before the Board for employee recognition from ISAC for their years of service with the County.
Discussion only. No action taken.

4. COMMITTEE APPOINTMENTS

Board discussed Committee meetings from the past week.
Board will hold a Town Hall meeting in Oakland on Tuesday, April 11 from 6:30 – 8:00 P.M at the Oakland Community Building.
Discussion only. No action taken.

5. RECEIVED/FILED

- A. Salary Action(s):
 - 1) Communications – Payroll status change for Torie Brummett, Abby Fredrich, and Elizabeth Sanders.
 - 2) Public Health – Payroll status change for Madhumitha Mohanraj.
- B. Out of State Travel Notification:
 - 1) Communications – Out of State Travel Notification for Merissa Cox and Alicia Cotten.
- C. Report(s):
 - 1) Sheriff’s Report of Fees Disbursed and Collected for February 2023.

6. PUBLIC COMMENTS

Geri Frederiksen appeared before the Board urging the Board to attend the meeting in Oakland concerning the Pipelines.

7. CLOSED SESSIONS

Motion by Wichman, second by Jorgensen, to go into Closed Session pursuant to Iowa Code 20.17.(3) for discussion and/or decision on labor negotiations/collective bargaining matters.

Roll Call Vote: AYES: Shea, Belt, Wichman, Miller, Jorgensen. Motion Carried.

Motion by Wichman, second by Belt, to go out of Closed Session.

Roll Call Vote: AYES: Shea, Belt, Wichman, Miller, Jorgensen. Motion Carried.

8. BUDGET STUDY SESSION

- A. Matt Wyant/Director, Planning and Development – Budget study session to include Public Health, Environmental Health, Animal Control, and Planning.
Discussion only. No action taken.

9. ADJOURN

Motion by Wichman, second by Jorgensen, to adjourn meeting.

UNANIMOUS VOTE. Motion Carried.

THE BOARD ADJOURNED SUBJECT TO CALL AT 1:23 P. M.

Brian Shea, Chairman

ATTEST:

Melvyn Houser, County Auditor

APPROVED: April 4, 2023

PUBLISH: X

Scheduled Sessions

**Jessica Rayment/Community Impact
Coordinator, Thriving Families Alliance**

**Discussion and/or decision to
approve and sign Proclamation
designating April 2023 as Child
Abuse Prevention Month**

**POTTAWATTAMIE COUNTY BOARD OF SUPERVISORS
PROCLAMATION**

CHILD ABUSE PREVENTION MONTH – APRIL 2023

WHEREAS, our children are our most valuable resource and provide hope for the future; and

WHEREAS, child abuse and neglect can have long-term effects that have lasting consequences for victims and affect every segment of our community; and

WHEREAS, together we can support safe, healthy families in our community by partnering to protect children; finding solutions with input and action from everyone; and

WHEREAS, communities must make every effort to support every child to have a great childhood and ensure families have the support needed to raise their children in safe, nurturing environments;

WHEREAS, we can promote the well-being of children and families, build resilience, and help to heal trauma.

NOW, THEREFORE, we, Pottawattamie County Board of Supervisors, do hereby proclaim April 2023 as Child Abuse Prevention Month and urge all citizens to recognize this month by dedicating ourselves to the task of improving the quality of life for all children and families.

ROLL CALL VOTE

	AYE	NAY	ABSTAIN	ABSENT
_____ Brian Shea, Chairman	<input type="radio"/>	<input type="radio"/>	<input type="radio"/>	<input type="radio"/>
_____ Scott Belt	<input type="radio"/>	<input type="radio"/>	<input type="radio"/>	<input type="radio"/>
_____ Tim Wichman	<input type="radio"/>	<input type="radio"/>	<input type="radio"/>	<input type="radio"/>
_____ Susan Miller	<input type="radio"/>	<input type="radio"/>	<input type="radio"/>	<input type="radio"/>
_____ Jeff Jorgensen	<input type="radio"/>	<input type="radio"/>	<input type="radio"/>	<input type="radio"/>

Attest:

Melvyn Houser, County Auditor
Pottawattamie County, Iowa

Westfair Board Members

**Discussion and/or decision on
capital projects.**

Tom Kallman/Manager, Regional Water

**Discussion and/or decision to
request additional funds for
water extension to Pioneer
Trail.**

John Rasmussen/County Engineer

Discussion and/or decision to approve and sign Contract to purchase Right of Way, from Joseph and Paula Lariviere in the amount of \$478.24.

CONTRACT

THIS AGREEMENT Made and entered into this 14th of March, A.D. 2023

By and between Joseph and Paula Lariviere

Address 14925 400th Street Carson, Iowa 51525
of the County of Pottawattamie, party of the first part, and Board of Supervisors, acting for Pottawattamie County Iowa, party of the second part.

WITNESSETH:

In consideration of \$478.24 receipt of which is hereby acknowledged, the party of the first part hereby agrees to furnish to the second party a warranty deed, or an easement for use as a public highway, to the real estate situated in the County of Pottawattamie, State of Iowa, to-wit:

In Section 11 Township 74N Range 40W

As shown on plans for Project No. L-2023(RCB)—73-78 Additional Rights of Way as follows:

See attached legal description.

It is hereby agreed that possession of the premises is the essence of this contract and that party of the second part may take immediate possession of the premises upon the signing of this contract for the purposes above set forth, and first party agrees to convey to second party for the consideration hereinafter named, on or before the 14th day of March, 2023.

Party of the second part agrees to purchase the above described real estate or take easement thereto for road purposes and to pay therefore upon delivery of warranty deed, or easement, showing merchantable title.

Approximately 0.034 acres at \$9,645.00 per acre	\$328.24
Allowance for abstract fee	\$150.00
TOTAL	\$478.24

Should the acreage taken for highway be more or less than shown above, same is to be paid for at the agreed unit price. Any and all verbal agreements are merged in this written contract. Should the highway as finally located require none of the real estate described, this contract becomes null and void.

Party of the first part consents to the establishment of the proposed road and relinquishes all claims for damages.

(Signed) Joe Lariviere
Party of the First Part

(Signed) POTTAWATTAMIE COUNTY

By _____, Chairman
Party of the Second Part

Document prepared by Pottawattamie County Engineer's Office

EASEMENT FOR PUBLIC HIGHWAY

KNOW ALL MEN BY THESE PRESENTS:

That Joseph & Paula Lariviere

14925 400th Street Carson, Iowa 51525

of Pottawattamie County, State of Iowa, in consideration of the sum of

Three hundred twenty-eight and 24/100 DOLLARS in hand paid by Pottawattamie County, do hereby sell and convey unto POTTAWATTAMIE COUNTY, for road purposes and for use as a Public Highway, the following described premises situated in the County of Pottawattamie, State of Iowa, to-wit:

Section 11-T74N-R40W
See attached legal description.

and we hereby covenant with the said POTTAWATTAMIE COUNTY that we are lawfully seized of said premises; that they are free from incumbrance; that we have good and lawful authority to sell and convey the same, and we do hereby covenant to warrant and defend the said premises against the lawful claims of all persons whomsoever, and the said Joseph & Paula Lariviere hereby relinquishes right of dower in and to the premises hereinbefore conveyed.

Signed this 14th day of March, A.D. 2023

Joseph Lariviere
Joseph Lariviere

Paula Lariviere
Paula Lariviere

State of Iowa }
Pottawattamie County, }

On this 14th day of MARCH, A.D. 2023, before me MICHAEL W. BONNET

a Notary Public in and for Pottawattamie County, State of Iowa, personally appeared

Joseph & Paula Lariviere

14925 400th Street Carson, Iowa 51525

to me known to be the person they named in and who executed the foregoing instrument, and acknowledged that they executed the same as their voluntary act and deed.

Michael W. Bonnet
Notary Public in and for said County

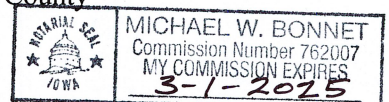

INSTRUCTIONS: IF THERE BE ANY ENCUMBRANCES, FILL OUT BLANK WAIVERS ON REVERSE SIDE.

DOCUMENT PREPARED BY POTTAWATTAMIE COUNTY ENGINEER'S OFFICE

RIGHT OF WAY ACQUISITION PLAT

ACQUIRED FROM LARIVIERE, JOSEPH & PAULA

I hereby certify that this surveying document was prepared and the related survey work was performed by me or under my direct personal supervision and that I am a duly licensed Land Surveyor under the laws of the State of Iowa.

James E. Terry 21 FEB. 2023
 James E. Terry, L.S. Date

License number 11702
 My license renewal date is December 31, 2023

Pages or sheets covered by this seal.
 Sheet 1 of 2 and Sheet 2 of 2.

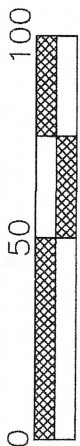
SCALE: 1" = 50'

LEGEND

- ▲ = FOUND 60d SPIKE IN ASPHALT
- △ = CORNER DESTROYED, CALC AND SET TEMP

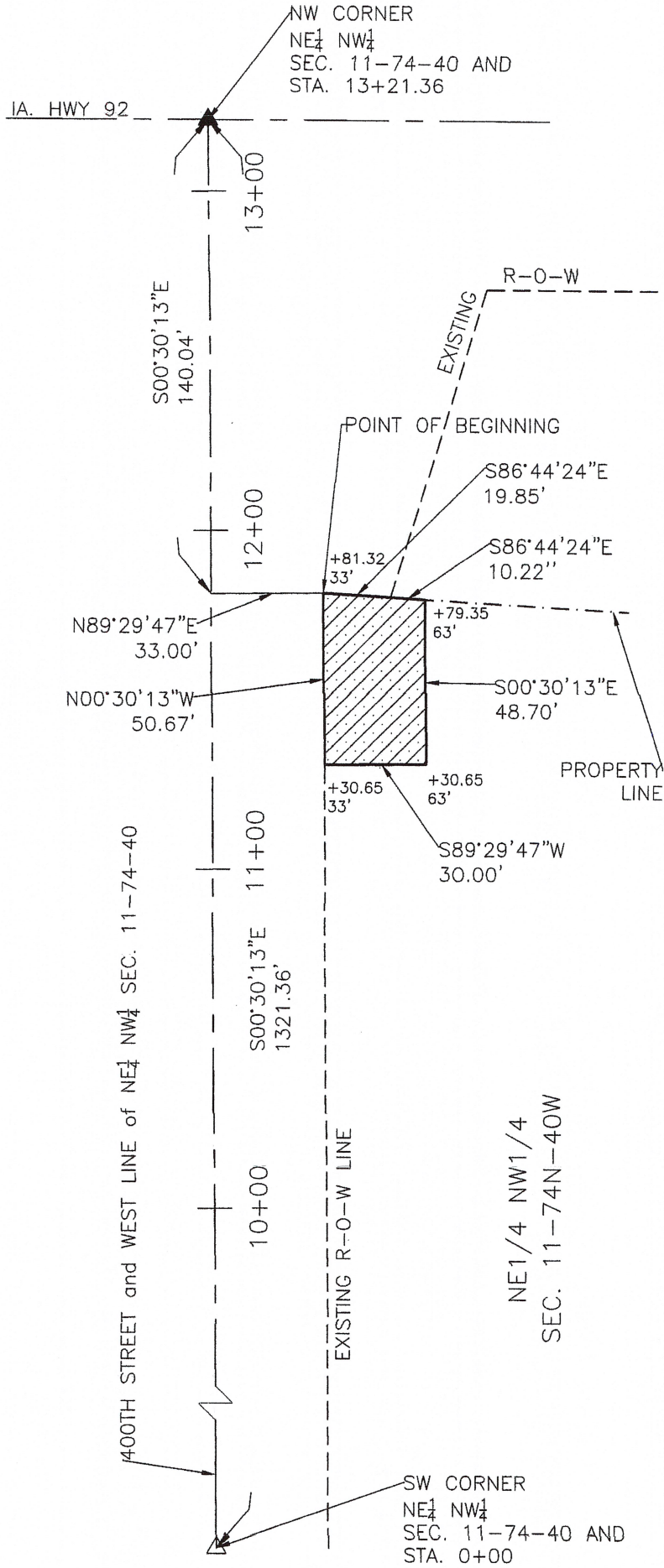

FROM ϕ STA. 11+30.65 TO ϕ STA. 11+81.32 R.O.W. 0.034 ACRES CONSIDERATION \$ _____

SECTION 11 TWP 74N RANGE 40W BORROW _____ ACRES

CIVIL TWP CARSON ACQUIRED BY PERM. ESMT CONTRACT DATED _____

Parcel No. 2

Legal Description:

A parcel of land located in part of the NE ¼ NW ¼ of Section 11, Township 74 North, Range 40 West of the 5th Principal Meridian in Pottawattamie County, Iowa, more particularly described as follows:

Commencing at the Northwest corner of the NE1/4 NW1/4 of said Section 11, thence S00°30'13"E along the West line of said NE1/4 NW1/4 a distance of 140.04 feet to a point being Station 11+81.32 on the West line of said NE1/4 NW1/4; thence N89°29'47"E a distance of 33.00 feet to a point on the East right-of-way line of 400th street and a point on the South right-of-way line of Primary Road No. Ia. 92, said point being Station 11+81.32, 33.00 feet right of the West line of said NE1/4 NW1/4 and the Point of Beginning; thence S86°44'24"E along said South right-of-way line of Primary Road No. Ia. 92, a distance of 19.85 feet; thence continuing S86°44'24"E on existing property line a distance of 10.22 feet to a point being Station 11+79.35, 63.00 feet right of the West line of said NE1/4 NW1/4; thence S00°30'13"E a distance of 48.70 feet to a point being Station 11+30.65, 63.00' right of the West line of said NE1/4 NW1/4; thence S89°29'47"W a distance of 30.00 feet to a point on said East right-of-way line of 400th Street, said point being Station 11+30.65, 33.00 feet right of the West line of said NE1/4 NW1/4; thence N00°30'13"W along said East right-of-way line a distance of 50.67 feet to the Point of Beginning. Said parcel contains 0.034 acres, more or less.

Note: The West line of the NE1/4 NW1/4 of said Section 11 is assumed to bear S00°30'13"E for this description.

John Rasmussen/County Engineer

Discussion and/or decision to approve and sign Contract to purchase Right of Way, from David and Darlene Pilling in the amount of \$623.05.

CONTRACT

THIS AGREEMENT Made and entered into this 16th of March, A.D. 2023

By and between David & Darlene Pilling L.L.C. & Dennis Dean Pilling

Address 14596 400th Street Carson, Iowa 51525

of the County of Pottawattamie, party of the first part, and Board of Supervisors, acting for Pottawattamie County Iowa, party of the second part.

WITNESSETH:

In consideration of \$623.05 receipt of which is hereby acknowledged, the party of the first part hereby agrees to furnish to the second party a warranty deed, or an easement for use as a public highway, to the real estate situated in the County of Pottawattamie, State of Iowa, to-wit:

In Section 11 Township 74N Range 40W

As shown on plans for Project No. L-2023(RCB)—73-78 Additional Rights of Way as follows:

See attached legal description.

It is hereby agreed that possession of the premises is the essence of this contract and that party of the second part may take immediate possession of the premises upon the signing of this contract for the purposes above set forth, and first party agrees to convey to second party for the consideration hereinafter named, on or before the 16th day of March, 2023.

Party of the second part agrees to purchase the above described real estate or take easement thereto for road purposes and to pay therefore upon delivery of warranty deed, or easement, showing merchantable title.

Approximately 0.049 acres at \$9,654.00 per acre	\$473.05
Allowance for abstract fee	<u>\$150.00</u>
TOTAL	\$623.05

Should the acreage taken for highway be more or less than shown above, same is to be paid for at the agreed unit price. Any and all verbal agreements are merged in this written contract. Should the highway as finally located require none of the real estate described, this contract becomes null and void.

Party of the first part consents to the establishment of the proposed road and relinquishes all claims for damages.

(Signed) 
Party of the First Part

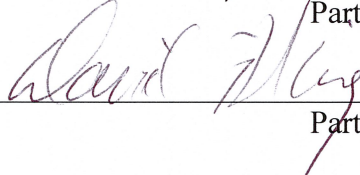
(Signed) 
Party of the First Part

(Signed) POTTAWATTAMIE COUNTY

By _____, Chairman
Party of the Second Part

Document prepared by Pottawattamie County Engineer's Office

EASEMENT FOR PUBLIC HIGHWAY

KNOW ALL MEN BY THESE PRESENTS:

That David & Darlene Pilling L.L.C. & Dennis Dean Pilling
14596 400th Street Carson, Iowa 51525

of Pottawattamie County, State of Iowa, in consideration of the sum of

Four hundred seventy-three and 05/100-----DOLLARS
in hand paid by Pottawattamie County, do hereby sell and convey unto POTTAWATTAMIE COUNTY, for road purposes and for use as a Public Highway, the following described premises situated in the County of Pottawattamie, State of Iowa, to-wit:

Section 11-T74N-R40W
See attached legal description.

and we hereby covenant with the said POTTAWATTAMIE COUNTY that we are lawfully seized of said premises; that they are free from incumbrance; that we have good and lawful authority to sell and convey the same, and we do hereby covenant to warrant and defend the said premises against the lawful claims of all persons whomsoever, and the said David & Darlene Pilling, & Dennis Pilling hereby relinquishes right of dower in and to the premises hereinbefore conveyed.

Signed this 16th day of March, A.D. 2023

Dennis Pilling
Dennis Pilling

David Pilling
David Pilling

Darlene Pilling
Darlene Pilling

State of Iowa }
Pottawattamie County,

On this 16TH day of MARCH, A.D. 2023, before me MICHAEL W. BONNET

a Notary Public in and for Pottawattamie County, State of Iowa, personally appeared

David & Darlene Pilling L.L.C. & Dennis Dean Pilling

14596 400th Street Carson, Iowa 51525

to me known to be the person they named in and who executed the foregoing instrument, and acknowledged that they executed the same as their voluntary act and deed.

Michael W. Bonnet
Notary Public in and for said County



DOCUMENT PREPARED BY POTTAWATTAMIE COUNTY ENGINEER'S OFFICE

RIGHT OF WAY ACQUISITION PLAT

ACQUIRED FROM DAVID & DARLENE PILLING L.L.C., & DENNIS DEAN PILLING

I hereby certify that this surveying document was prepared and the related survey work was performed by me or under my direct personal supervision and that I am a duly licensed Land Surveyor under the laws of the State of Iowa.

James E. Terry
James E. Terry, L.S.
License number 11702
Date 11 MAR. 2023

My license renewal date is December 31, 2023

Pages or sheets covered by this seal.
Sheet 1 of 2 and Sheet 2 of 2.

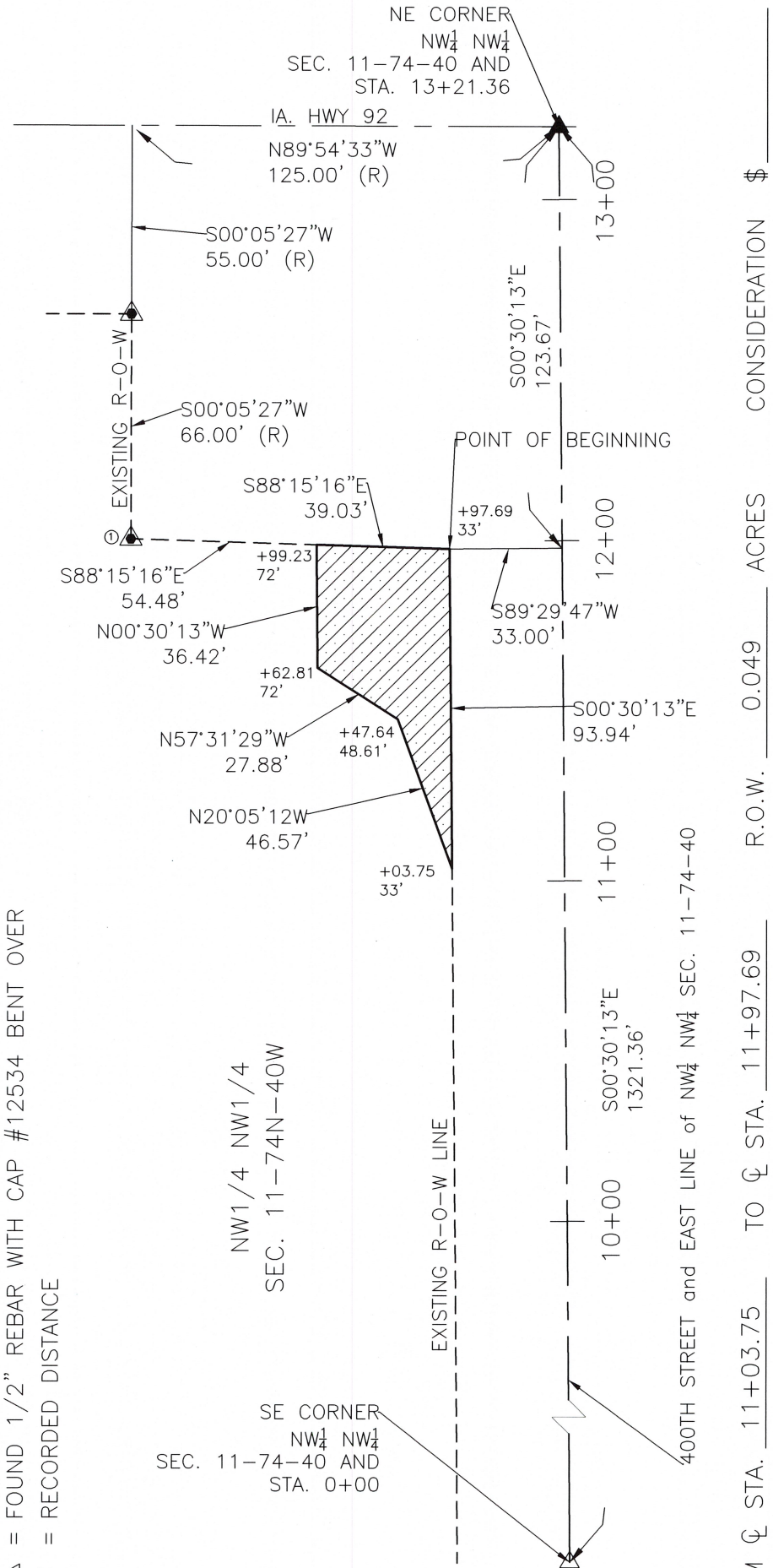
FROM \varnothing STA. 11+03.75 TO \varnothing STA. 11+97.69 R.O.W. 0.049 ACRES CONSIDERATION \$ _____

SECTION 11 TWP 74N RANGE 40W BORROW _____ ACRES

CIVIL TWP CARSON ACQUIRED BY PERM. ESMT CONTRACT DATED _____

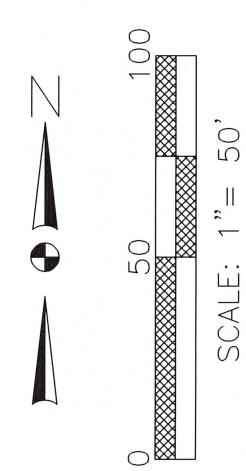

- LEGEND**
- ▲ = FOUND 60d SPIKE IN ASPHALT
 - △ = CORNER DESTROYED, CALC AND SET TEMP
 - ▲ = FOUND 1/2" REBAR WITH CAP #12534
 - ⊙▲ = FOUND 1/2" REBAR WITH CAP #12534 BENT OVER
 - R = RECORDED DISTANCE

Parcel No. 1

Legal Description:

A parcel of land located in part of the NW ¼ NW ¼ of Section 11, Township 74 North, Range 40 West of the 5th Principal Meridian in Pottawattamie County, Iowa, more particularly described as follows:

Commencing at the Northeast corner of the NW1/4 NW1/4 of said Section 11, thence S00°30'13"E along the East line of said NW1/4 NW1/4 a distance of 123.67' to a point being Station 11+97.69 on the East line of said NW1/4 NW1/4; thence S89°29'47"W a distance of 33.00 feet to a point on the West right-of-way line of 400th Street, said point being Station 11+97.69, 33.00 feet left of the East line of said NW1/4 NW1/4 and the Point of Beginning; thence S00°30'13"E along said West right-of-way line of 400th Street a distance of 93.94 feet to a point being Station 11+03.75, 33.00 feet left of the East line of said NW1/4 NW1/4; thence N20°05'12"W a distance of 46.57 feet to a point being Station 11+47.64, 48.61 feet left of the East line of said NW1/4 NW1/4; thence N57°31'29"W a distance of 27.88 feet to a point being Station 11+62.81, 72.00 feet left of the East line of said NW1/4 NW1/4; thence N00°30'13"W a distance of 36.42 feet to a point being Station 11+99.23, 72.00 feet left of the East line of said NW1/4 NW1/4, said point also being on the South right-of-way line of Primary Road No. Ia. 92; thence S88°15'16"E along said South right-of-way line of Primary Road No. Ia. 92 a distance of 39.03 feet to the Point of Beginning. Said parcel contains 0.049 acres, more or less.

Note: The East line of the NW1/4 NW1/4 of said Section 11 is assumed to bear S00°30'13"E for this description.

John Rasmussen/County Engineer

Discussion and/or decision to approve and authorize the Board to sign Resolution NO. 20-2023 entitled: RESOLUTION TO PROCEED BY EMINENT DOMAIN PURSUANT TO IOWA CODE §6B.2C TO CONDEMN REAL ESTATE IN POTTAWATTAMIE COUNTY, IOWA FOR THE PURPOSES OF CONSTRUCTING ROAD IMPROVEMENTS ON DUMFRIES AVENUE FROM ASPEN ROAD TO PIONEER TRAIL.

RESOLUTION NO. 20-2023

RESOLUTION TO PROCEED BY EMINENT DOMAIN PURSUANT TO IOWA CODE §6B.2C TO CONDEMN REAL ESTATE IN POTTAWATTAMIE COUNTY, IOWA FOR THE PURPOSES OF CONSTRUCTING ROAD IMPROVEMENTS ON DUMFRIES AVENUE FROM ASPEN ROAD TO PIONEER TRAIL

WHEREAS the County has implemented plans to upgrade and pave Dumfries Avenue from Aspen Road to Pioneer Trail in Pottawattamie County, Iowa; and

WHEREAS there is a reasonable expectation that the County will be able to achieve its public purpose and comply with all applicable standards for the same; and

WHEREAS the laws of the State of Iowa require the passage of a resolution by the County prior to its implementation of eminent domain by condemnation proceeding pursuant to the Iowa Code; and

WHEREAS a Temporary Easement for purposes of roadway improvement and construction, and a Permanent Easement for roadway purposes, is required to achieve the goals of the public improvement project; and

WHEREAS the County has unsuccessfully attempted to negotiate the voluntary sale of property necessary for the completion of the project prior to initiating eminent domain proceedings.

NOW THEREFORE, BE IT RESOLVED by the Board of Supervisors of Pottawattamie County, Iowa that the County approves proceeding by eminent domain pursuant to the laws of the State of Iowa to condemn the property owned by Henry C. Brandt, Jr., Linda Brandt, Jane Triptow, Barbara Frederick, and Vic Frederick legally described as:

A portion of Section 24, Township 74 North, Range 43 West in Pottawattamie County, Iowa, more specifically described in the Permanent Easement Plat and Temporary Easement exhibits attached to this Resolution.

PASSED AND APPROVED this 4th day of April, 2023.

ROLL CALL VOTE

	AYE	NAY	ABSTAIN	ABSENT
_____ Brian Shea, Chairman	<input type="radio"/>	<input type="radio"/>	<input type="radio"/>	<input type="radio"/>
_____ Scott Belt	<input type="radio"/>	<input type="radio"/>	<input type="radio"/>	<input type="radio"/>
_____ Tim Wichman	<input type="radio"/>	<input type="radio"/>	<input type="radio"/>	<input type="radio"/>
_____ Susan Miller	<input type="radio"/>	<input type="radio"/>	<input type="radio"/>	<input type="radio"/>
_____ Jeff Jorgensen	<input type="radio"/>	<input type="radio"/>	<input type="radio"/>	<input type="radio"/>

ATTEST: _____
Melvyn Houser, County Auditor

Recommended: _____
Pottawattamie County Engineer

Other Business

David Bayer/Chief Information Office, IT

**Discussion and/or decision to
approve updated IT Computer
Replacement Policy.**

Title: Computer Replacement Policy
Effective Date: November 23, 2011
Revision Date: March 29, 2023
Authorized by: County Board of Supervisors

Introduction

This Computer Replacement Policy (CRP) is an effort to keep Pottawattamie County's computer technology current and standardized through scheduled replacement.

Goals

The goal is to ensure that County staff has up-to-date computer equipment that is both serviceable and in good working order. To achieve this, the following objectives should be sought:

- Centralize the budgeting of basic computing resources for County employees, thereby providing relief to department budgets and reducing reliance on year-end surplus.
- Implement standards for computing resources and increase the supportability of the County's computer base.
- Streamline the specification, acquisition, and deployment of new equipment and re-deployment or disposal of old equipment.
- Maximize revenue return through the sale or strategic reuse of old computer equipment.

Policy Guidelines and Process

Each year PCIT will budget for the replacement of 20% of County personal computers. PCIT will target the oldest County computers first.

Qualified Participants within Each Department

Provided that they require computing resources, the following positions will be targeted for computer replacement:

- Full-Time Positions
- Part-Time Permanent Positions
- One (1) computing device will be procured per position

Computer Replacement Process, Specifications and Selection

PCIT staff will evaluate each department's needs and their current stock of computing hardware for the given fiscal year to develop a replacement/upgrade plan. This evaluation will include, but is not limited to the following tasks:

- Decide what will be replaced or upgraded, then build specifications for that hardware.
- Decide what virtual desktops need upgraded and what upgrades are required.

The standard form factors include desktops, laptops, virtual desktops, and tablets. The following guidelines should be used to assist in the choice of equipment:

- The standard desktop is intended for general office duties, such as word processing, spreadsheets, electronic messaging, and web browsing, making it suitable for most office needs.
- The laptop configuration combines general office productivity with portability. The standard laptop configuration is suitable for staff who intend to use the computer remotely.

- For virtual desktops, PCIT staff will review what is in place and make necessary improvements (i.e., OS upgrades, RAM adjustments, etc.). This hardware will be replaced as needed independent of this policy.
- Tablets are highly portable and easy to use but not typically intended as a primary computing device. Tablets are only replaced and purchased by PCIT when it is the singular device for the position.

Communication

Once the computer replacement/upgrade plan has been determined for the scheduled departments (see replacement schedule at end of this document), the department head or designated department liaison will be contacted to discuss the following:

- Which computers will be replaced
- Which computers will be upgraded
- Which virtual desktops will be upgraded
- Specifications requested by the department beyond what is recommended by PCIT staff will be charged to the individual department.
- Additional computer accessories needed (i.e., docking stations, monitors, scanners, etc.) will be ordered by PCIT to ensure compatibility, but charged to the individual department.

Resource Procurement

Computers are purchased by PCIT in bulk fashion to maximize savings. They are charged against the PCIT budget and delivered to the PCIT Department. PCIT staff will install the standard image and process the computers for County use, which includes inventorying into County systems.

Resource Deployment

Computers procured through the Computer Replacement Policy are installed by PCIT. Every effort will be made to provide a flexible installation schedule that causes minimal downtime.

Redeployment and Disposal

Computers that have been replaced will be repurposed within the County, auctioned off, donated locally to non-profits or schools, or recycled. Revenues recovered from the sale of used computing resources will be returned to the County's General Fund.

Replacement Schedule

Department	Year
Avoca CH	1
Conservation	1
Planning & Animal Control	1
Sheriff's Office & Conservation MDT's	1
Attorney	2
Medical Examiner	2
Public Health & WIC	2
Buildings & Grounds	3
Community Services	3
Human Resources	3
Training Laptops	3
Treasurer	3
Veteran Affairs	3
911 (Courthouse)	4
BOS	4
Secondary Roads	4
GIS	4
Jail	4
Recorder	4
Auditor	5
PCIT	5
Sheriff's Office (including Court Security)	5

Matt Wilber/Attorney

**Discussion and/or decision on
pay for Victim Witness
Coordinator.**

Received/Filed

Committee Appointments

Update from Board members on Committee meetings from the past week.

Public Comments

Closed Session

Study Session